

FATBOY SERIES

The Remco Fatboy Series is the most powerful pump for its size. Demanding industrial environments require precise engineering with high quality components. The Fatboy Series was designed with this in mind.



PRESSURE RANGE: 60 - 100 PSI

OPEN FLOW SETTING: 7.0 GPM

PUMP OPTIONS

- FLUID PORTS: 3/4" QUICK ATTACH OR 1/2" FNPT
- VOLTAGE: 12 / 24 VDC OR 115 VAC
- MATERIALS: VITON / SANTOPRENE / NYLON / POLY
- DEMAND / BYPASS / DUAL CONTROL / NO CONTROL
- MOTORS: HEAVY DUTY / SEALED / LOW OR HIGH SPEED
- PACKAGING: BULK / SINGLE BOX / RETAIL AVAILABLE
- MANY OTHER OPTIONS AVAILABLE

STANDARD FEATURES

- PROFESSIONAL GRADE QUALITY
- MADE IN THE UNITED STATES
- 100% FACTORY TESTED PERFORMANCE
- COMPLETELY SEALED MOTOR
- HIGH PERFORMANCE AT WORKING PRESSURE
- SUPERIOR VERTICAL PRIMING

TYPICAL APPLICATIONS

- LIQUID DEICING
- EQUIPMENT WASHDOWN
- ROAD MAINTENANCE
- AG AND INDUSTRIAL CHEMICAL SPRAYING
- DUST SUPPRESSION

PUMP DIMENSIONS

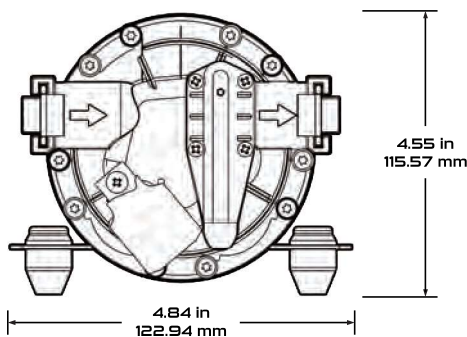

TECHNICAL INFORMATION

- 12 AWG - 12" LEAD WIRE / CUSTOM CONNECTION
- 14FT (4.0M) PRIMING CAPABILITY
- INTERMITTENT DUTY CYCLE
- DRY RUN CAPABILITY
- 140°F (60°C) MAX LIQUID TEMPERATURE
- 180°F (82°C) MAX MOTOR TEMPERATURE

PUMP PERFORMANCE

(PERFORMANCE MAY VARY)

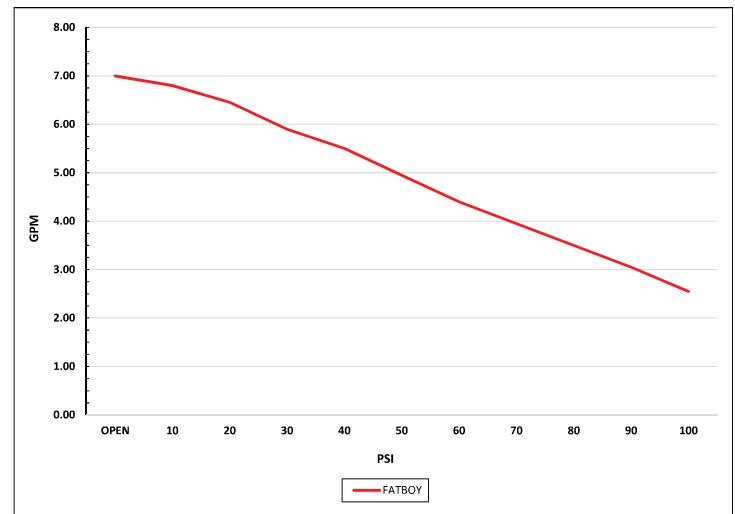

(DIMENSIONS MAY VARY BY MODEL)

