



FUEL MANAGEMENT SYSTEMS



DISPENSERS



KITS



PUMPS



METERS



NOZZLES

PITSTOP

FEATURES

- **READY TO INSTALL**
- **VERSATILITY**
- **STURDY STRUCTURE**

The PIUSI PITSTOP is a dispenser unit with two DC pumps, automatic hose reel, water filter and automatic nozzle with 14 meter. hose integrated into a sturdy supporting structure. Easy to install, versatile and compact, this dispenser is the all-in-one solution for setting up a perfect mobile refueling unit.

PERFORMANCE

UP TO

45 L/MIN

FLOW RATE

12/24V

VOLTAGE

POWER

14MT

HOSE LENGTH

HOSE REEL

200β/30μ

FILTERING CAPACITY



PITSTOP



PACKAGING

CODE	WEIGHT		PACKAGING		
	KG	LBS	MM	INCH	PCS/BOX
FO0212000	45	99	595X465X670	23,4X13,5X24,4	1
FO0213000	45	99	595X465X670	23,4X13,5X24,4	1



FILTRATION



TANK MONITORING



HOSE REEL



ACCESSORIES



MERCHANDISE

PIUSI

BIS

ANY BIODIESEL

A

AIR

A

ANTIFREEZE

Ad

AdBlue®

B

BIODIESEL

D

DIESEL

F

FOOD

G

GASOLINE

G

GREASE

K

KEROSENE

O

OIL

W

WATER

W

WINDSCREEN

CHART

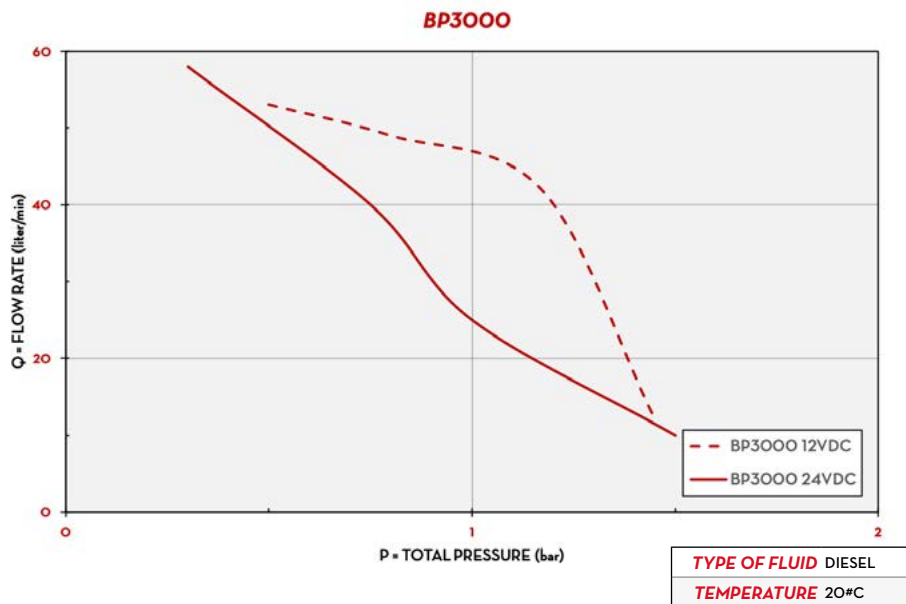

DIMENSIONS

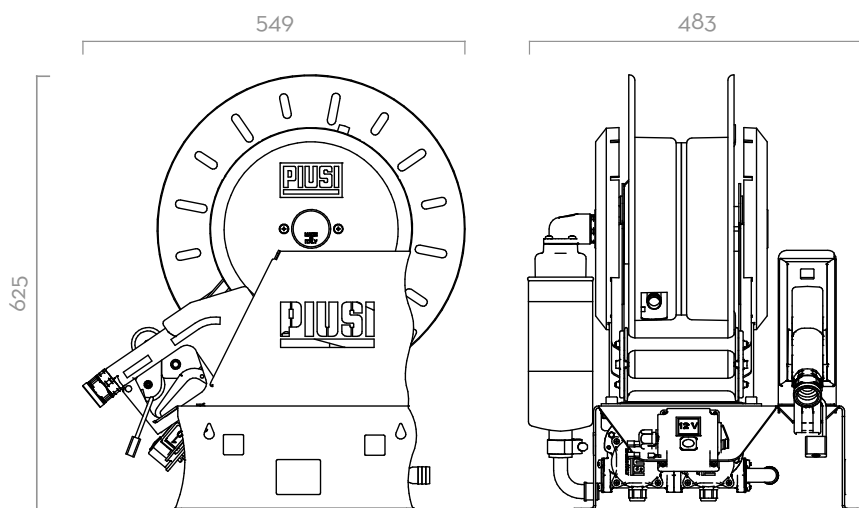

Dimensions expressed in millimeters

IN THE BOX

- PITSTOP UNIT
- AUTOMATIC NOZZLE
- FILTER
- INSTRUCTION MANUAL

DETAILS



ON/OFF SWITCH



PAD LOCK



BUILT-IN DC PUMPS



ADJUSTABLE ARM

COMPONENTS

- **PUMP:**
BP3000
- **FILTER:**
WATER CAPTOR
- **NOZZLE:**
A60

TECHNICAL DATA

CODE	DESCRIPTION	FLUIDS TYPE	FLOW RATE		VOLTAGE			PUMP		DUTY CYCLE	NOZZLE	HOSE	INLET	
			L/MIN	GPM	AC V/ HZ	DC VOLT	POWER WATT	AMP. MAX.	TYPE	N°	MINUTES	TYPE	LENGTH	Ø
FOO212000	PIUSI PITSTOP DC 12V	D	45	11,9	12	400	33	BP 3000	2	30	A60	14M	3/4"	1"
FOO213000	PIUSI PITSTOP DC 24V	D	45	11,9	24	620	26	BP 3000	2	30	A60	14M	3/4"	1"