



KITS



PUMPS



METERS



METERED NOZZLES



NOZZLES



WASTE OIL EQUIPMENTS

K600/3

FEATURES

- ADJUSTABLE FLANGES
- EXTREMELY ACCURATE
- SUITABLE FOR INDUSTRIAL APPLICATIONS
- IDEAL FOR MOBILE INSTALLATIONS
- LOW ENERGY CONSUMPTIONS

The PIUSI K600/3 is an oval gear meter suitable for measuring the delivery of low, medium and high viscosity oils. The meter is equipped with an integrated filter and it is available also in pulser version.

PERFORMANCE

UP TO 6-60 L/MIN	30-70BAR
FLOW RATE	OPERATING PRESSURE
± 0,5%	0,2%
ACCURACY	REPEATABILITY

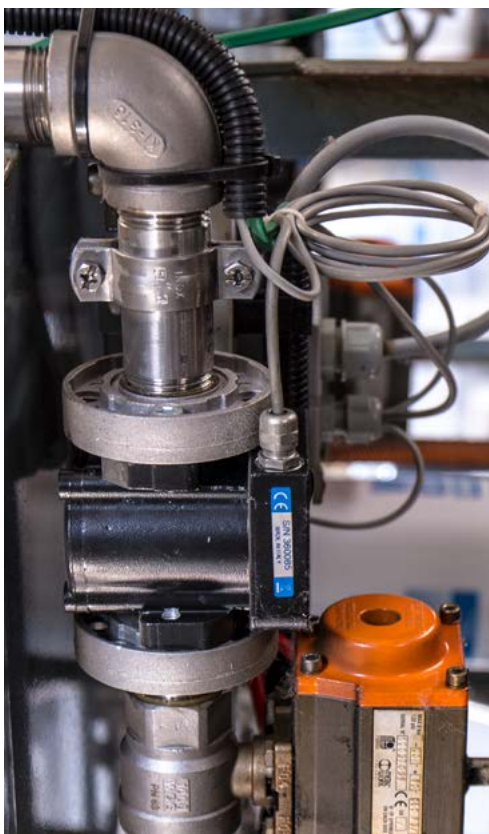

K600/3

K600/3 PULSER

PACKAGING

CODE	WEIGHT		PACKAGING			
	KG	LBS	MM	INCH	PCS/PALLET	PCS/BOX
METERS						
FOO496A20	1,6	3,5	200X120X140	7,9X4,7X5,5		1
PULSER						
FOO472A20	2	4,4	200X120X140	7,9X4,7X5,5		1



FILTRATION



FLUID MONITORING



TANK MONITORING



HOSE REELS



ACCESSORIES



MERCHANDISE



AIR



ANTIFREEZE



AdBlue®



BIODIESEL



DIESEL



FOOD



GASOLINE



GREASE



KEROSENE



OIL



WATER



WINDSCREEN

CHART

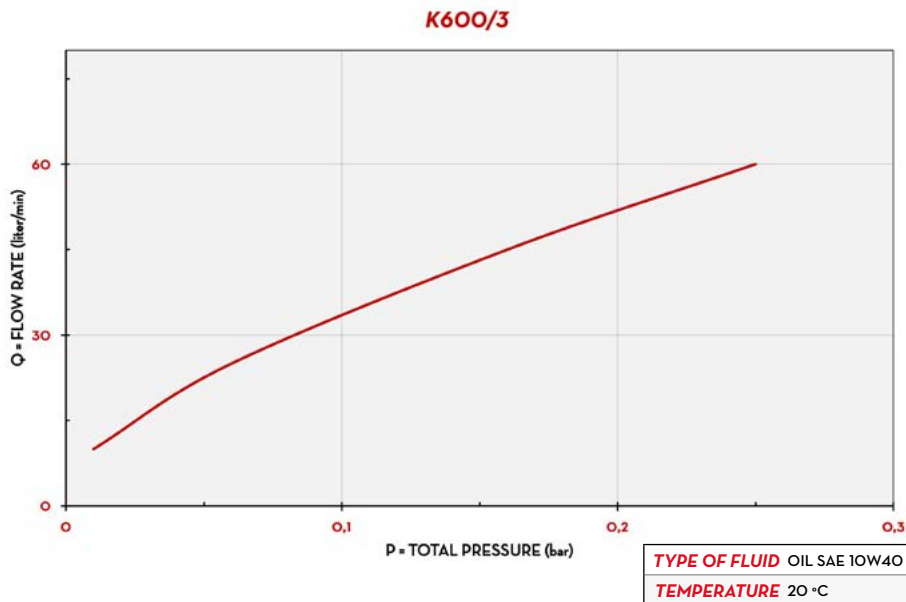

IN THE BOX

- K600/3 METER
- INSTRUCTION MANUAL

DETAILS



RESET / CALIBRATE BUTTON



OVAL GEAR



ALLUMINIUM BODY

DIMENSIONS

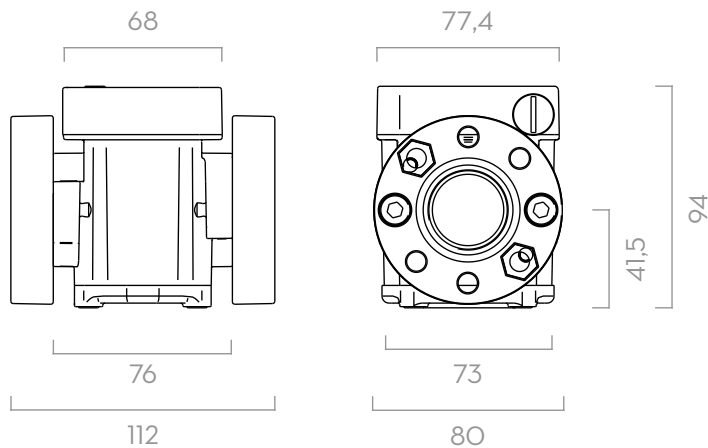

Dimensions expressed in millimeters

MATERIALS

- BODY: ALLUMINIUM
- GEARS: TECHNOPOLYMER

TECHNICAL DATA

CODE	DESCRIPTION	FLUIDS TYPE	FLOW RATE		WORKING PRESSURE		BATTERY INCLUDED NO. 2 2X1,5V	FLANGE	INLET OUTLET	INLET FILTER
			L/MIN	GPM	BAR	PSI				
METER FOO496A20	K600/3 METER " BSP OIL		6 - 60	1,58 - 1,58	70	994	YES	YES	3/4" BSP	YES
PULSER FOO472A20	K600/3 PULSER " BSP OIL		6 - 60	1,58 - 1,58	70	994	NO	YES	3/4" BSP	YES

UPON REQUEST AVAILABLE IN NPTF VERSION AND DISPLAY IN GALLON/QUARTER OR PRINT