



KITS



PUMPS



METERS



METERED NOZZLES



NOZZLES



WASTE OIL EQUIPMENTS

K600/4

FEATURES

- ADJUSTABLE FLANGES
- INSTANTANEOUS READING
- EXTREMELY ACCURATE
- SUITABLE FOR INDUSTRIAL APPLICATIONS
- IDEAL FOR MOBILE INSTALLATIONS
- LOW ENERGY CONSUMPTION

The PIUSI K600/4 is an oval gear meter suitable for monitoring the delivery of low and medium viscosity oils. Its 4 couples of gears allows to reach high flow rates.

PERFORMANCE

UP TO 15-150 L/MIN	20 BAR
FLOW RATE	OPERATING PRESSURE
± 0,5 %	0,2%
ACCURACY	REPEATABILITY



K600/4



K600/4 PULSER

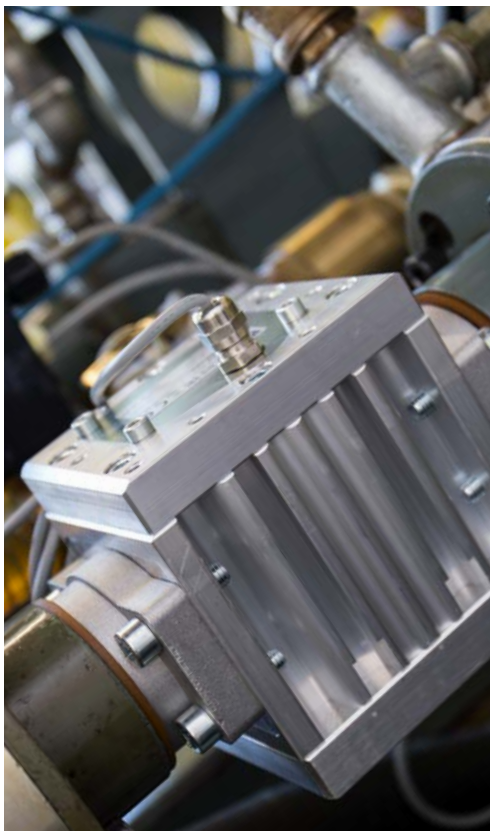

PACKAGING

CODE	WEIGHT		PACKAGING			
	KG	LBS	MM	INCH	PCS/PALLET	PCS/BOX

METER

00049700A	3,2	7	200X120X140	7,9X4,7X5,5		1
-----------	-----	---	-------------	-------------	--	---



FILTRATION



FLUID MONITORING



TANK MONITORING



HOSE REELS



ACCESSORIES



MERCHANDISE



AIR



ANTIFREEZE



AdBlue®



BIODIESEL



DIESEL



FOOD



GASOLINE



GREASE



KEROSENE



OIL



WATER



WINDSCREEN

CHART

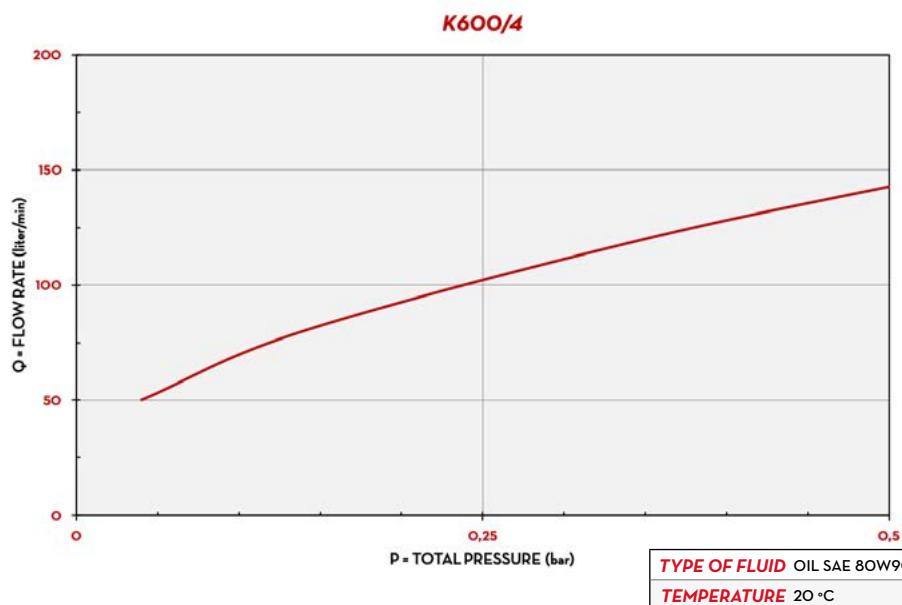

IN THE BOX

- K600/4 METER
- INSTRUCTION MANUAL

DETAILS



RESET / CALIBRATE BUTTON



OVAL GEAR



ALLUMINIUM BODY

DIMENSIONS

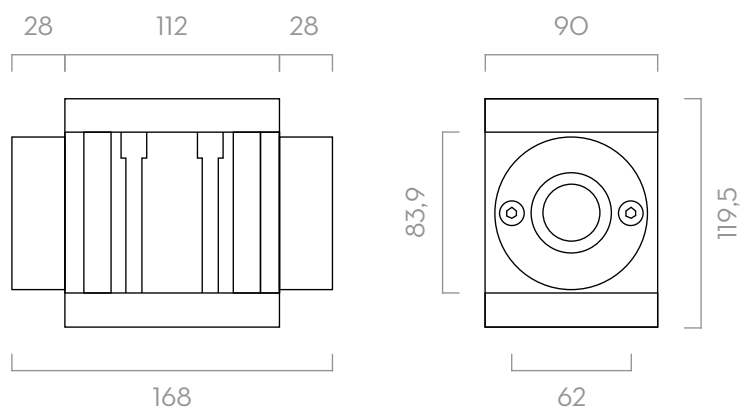

Dimensions expressed in millimeters

MATERIALS

- BODY: ALLUMINIUM
- GEARS: TECHNOPYLIMER

TECHNICAL DATA

CODE	DESCRIPTION	FLUIDS TYPE	FLOW RATE		WORKING PRESSURE		BATTERY INCLUDED NO. 2 2X1,5V	FLANGE	INLET OUTLET	INLET FILTER
			L/MIN	GPM	BAR	PSI				

METER

00049700A	K600/4 METER 1." BSP		15 - 150	3,9 - 39	20	284	YES	YES	1 1/2" BSP	YES
-----------	----------------------	--	----------	----------	----	-----	-----	-----	------------	-----

UPON REQUEST AVAILABLE IN NPTF VERSION AND DISPLAY IN GALLON/QUARTER OR PINT