



FUEL MANAGEMENT SYSTEMS



DISPENSERS



KITS



PUMPS



METERS



NOZZLES

K24

FEATURES

- BURSTING PRESSURE 100 BAR
- LCD DISPLAY
- FLOW RATE INDICATION
- EASY TO CALIBRATE

The PIUSI K24 is a turbine digital flow meter specifically designed for diesel. Easy to install in-line or at the end of a delivery pipe, it is equipped with a rotatable display. This meter is available both with aluminium or technopolymer body.



PERFORMANCE

7-120

L/MIN
FLOW RATE

20 BAR

MAX
OPERATING PRESSURE

± 1%

ACCURACY

0,2%

REPEATABILITY



K24 plastic version



K24 PULSER

K24

PACKAGING

CODE	WEIGHT		PACKAGING		
	KG	LBS	MM	INCH	PCS/BOX
K24					
FOO40700A	0,5	1,1	BLISTER	BLISTER	1
FOO408100	0,5	1,1	BLISTER	BLISTER	1
K24 PULSER					
FOO40722A	0,5	1,1	115X16OX135	4,5X6,3X5,3	1



FILTRATION



TANK MONITORING



HOSE REEL



ACCESSORIES



MERCHANDISE

PIUSI



ANY BIODIESEL



AIR



ANTIFREEZE



AdBlue®



BIODIESEL



DIESEL



FOOD



GASOLINE



GREASE



KEROSENE



OIL



WATER



WINDSCREEN

CHART

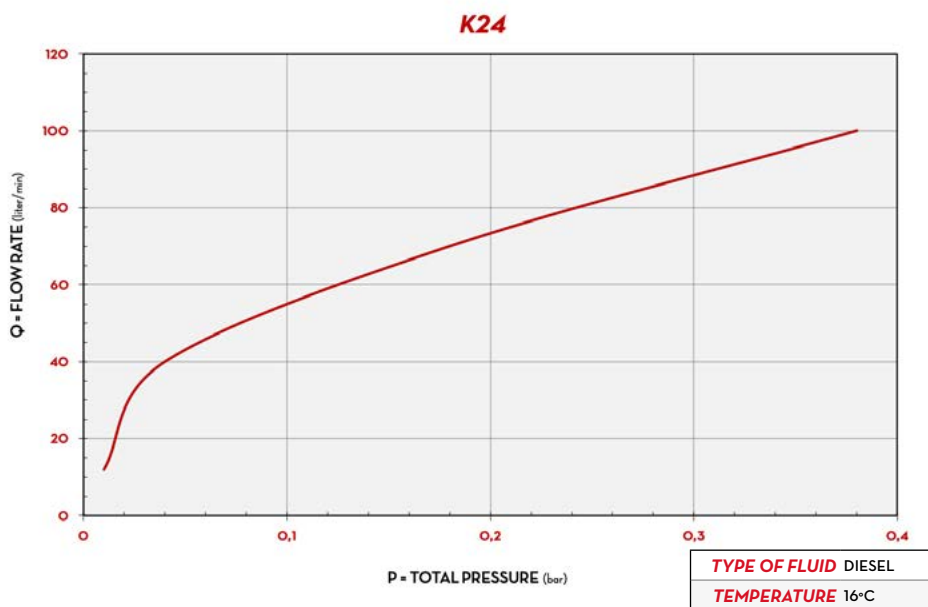

DIMENSIONS

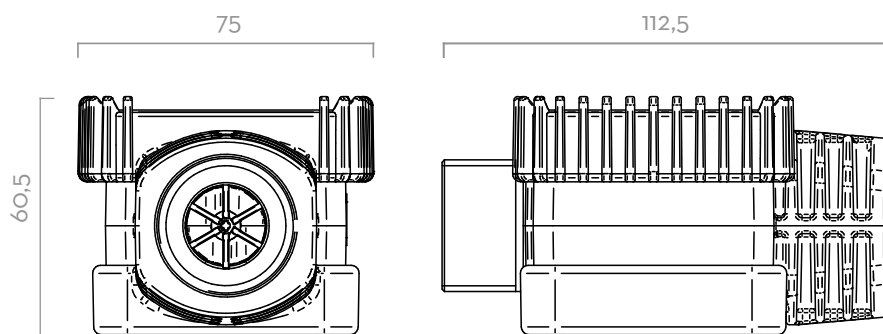

Dimensions expressed in millimeters

IN THE BOX

- K24 METER
- INSTRUCTION MANUAL

DETAILS



MATERIALS

- BODY: ALUMINIUM
- GEARS: TECHNOPOLYMER

TECHNICAL DATA

CODE	DESCRIPTION	FLUIDS TYPE	FLOW RATE		PRESSURE		BATTERY	FLANGE	INLET / OUTLET
			L/MIN	GPM	BAR	PSI	2X AAA BATTERY 1,5V (INCLUDED)		
K24									
FOO40700A	K24 METER M/MF LITER BLACK 1INBSP	D	7 - 120	2 - 32	10	150	YES	NO	M 1" BSP - M 1" BSP
FOO408100	K24 M/F 1" BSP	D	7 - 120	2 - 32	20	300	YES	NO	M 1" BSP - F 1" BSP
K24 PULSER									
FOO40722A	K24 PULSER M/MF LITER BLACK 1INBSP	D	7 - 120	2 - 32	10	150	NO	NO	M 1" BSP - M 1" BSP

UPON REQUEST AVAILABLE IN NPTF VERSION AND DISPLAY IN GALLON/QUARTER OR PRINT
N° 2X1,5V BATTERY INCLUDED