



FUEL MANAGEMENT SYSTEMS



DISPENSERS



KITS



PUMPS



METERS



NOZZLES

EX140



FEATURES

- HIGH FLOW RATE
- HEAVY DUTY
- CONTINUOUS DUTY
- THERMAL PROTECTION
- UL VERSION AVAILABLE
- REMOVABLE PUMP FEET

The entirely new EX line is characterized by a high flow rate that works with a continuous duty cycle, and has been designed to be particularly suitable for Heavy Duty, i.e. for those demanding fleets that need to dispense fuels such as Gasoline, diesel or kerosene quickly.

PERFORMANCE

UP TO
140 L/MIN

FLOW RATE

AC
VOLTAGE

POWER



EX140

OUR PUMPS COMPLIES WITH THE FOLLOWING MARKING ATEX/IECEX

II	2	G	Ex	d	IIA	T4	Gb
GROUP	CATEGORY	TYPE OF EXPLOSIVE ATMOSPHERE	PERMANENT PREFIX	PROTECTION METHOD	GAS GLASS	TEMPERATURE CLASS	EQUIPMENT PROTECTION LEVEL

PACKAGING

CODE	WEIGHT		PACKAGING		
	KG	LBS	MM	INCH	PCS/BOX
FO0395010	25	55	240X400X350	9,4X15,7X13,8	1
FO0395020	25	55	240X400X350	9,4X15,7X13,8	1
FO0395030	25	55	240X400X350	9,4X15,7X13,8	1



FILTRATION



TANK MONITORING



HOSE REEL



ACCESSORIES



MERCHANDISE



ANY BIODIESEL



AIR



ANTIFREEZE



AdBlue®



BIODIESEL



DIESEL



FOOD



GASOLINE



GREASE



KEROSENE



OIL



WATER



WINDSCREEN

CHART

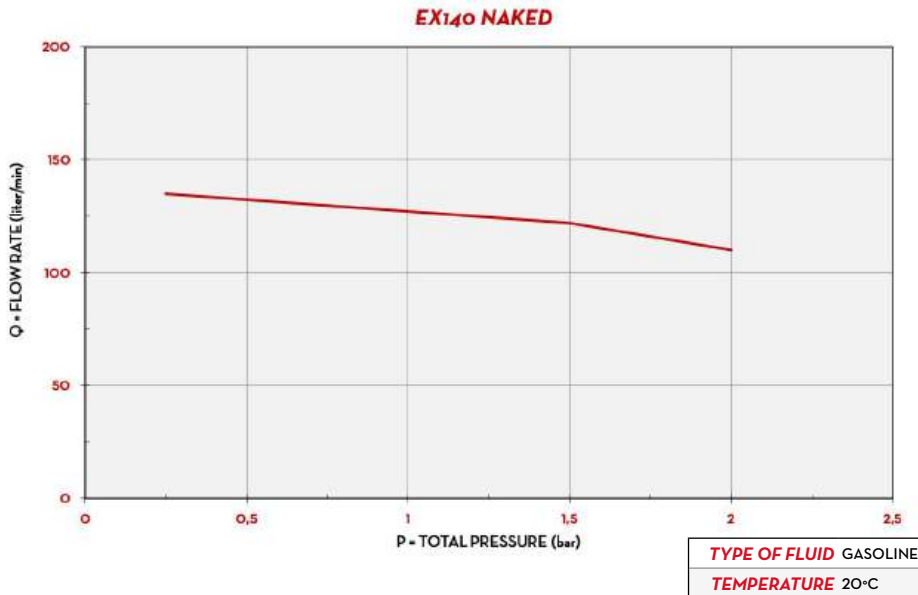

DIMENSIONS

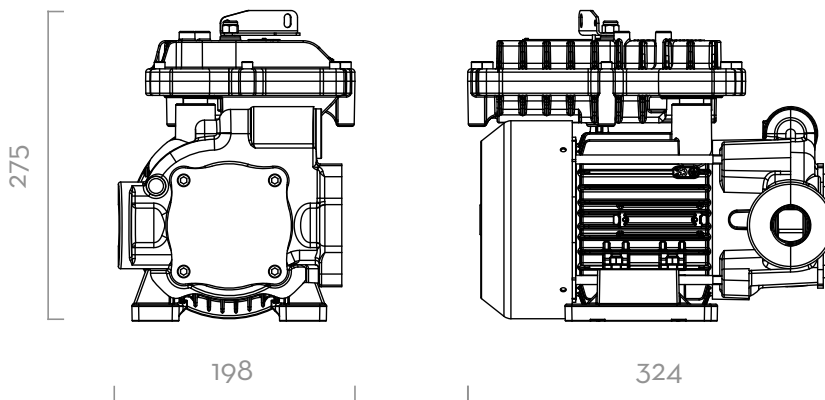

Dimensions expressed in millimeters

IN THE BOX

- EX140 PUMP
- PUMP FEET
- INSTRUCTION MANUAL

DETAILS



ON/OFF SWITCH



VANE ROTOR



BYPASS VALVE

MATERIALS

- BODY: CAST IRON
- ROTOR: SINTERED STEEL
- VANES: TECHNOPYLIMER
- SEAL: VITON
- SHAFT: STEEL



PUMP

- > MAX 6M (20FT),
- > SUCTION HOSE Ø 1" MIN,
- > MAX SUCTION HEIGHT:
 - 2M (7FT) W/O NON RETURN VALVE
 - 4M (14FT) W NON RETURN VALVE



TANK

TECHNICAL DATA

CODE	DESCRIPTION	FLUIDS TYPE	FLOW RATE		VOLTAGE			DUTY CICLE	RPM	INLET		OUTLET	
			L/MIN	GPM	AC VOLT/HZ	POWER WATT	AMP. MAX.	CONTINUOUS		BSP	BSP		
FO0395010	EX 140 230/50	D G K	140	37	230/50	1150	5	YES	1450	1" 1/4	1"		
FO0395020	EX 140 250/50	D G K	140	37	250/50	1125	4,5	YES	1450	1" 1/4	1"		
FO0395030	EX 140 230/60	D G K	140	37	230/60	920	4	YES	1750	1" 1/4	1"		

() UPON REQUEST IT IS AVAILABLE WITH DIFFERENT VOLTAGES AND 60 HZ FREQUENCY. COMPATIBLE FLUIDS: DIESEL, KEROSENE, PETROL, PETROL ALCOHOL MIXED MAX 15%, AVGAS 100/100LL (ONLY PUMP), JET A/A1 (ONLY PUMP), ASPEN 2/4