



FUEL MANAGEMENT SYSTEMS



DISPENSERS



KITS



PUMPS



METERS



NOZZLES

# DRUM

## FEATURES

- EASY TO INSTALL
- SUITABLE FOR ALL DRUMS
- DIFFERENT PUMPS FOR ANY NEED
- AC/DC VERSIONS

The PIUSI DRUM is a compact fuel transfer unit suitable to be connected on drums thanks to the quick 2" coupling. Available with different pumps, the system is (always) equipped with a telescopic suction hose and the nozzle holder located above the drum, near the pump, for easy, clean and safe operations. K33 mechanical meter available on request.

### PERFORMANCE

UP TO

**80 L/MIN**

FLOW RATE

**AC/DC**

VOLTAGE

POWER

**± 1%**

ACCURACY



DRUM PANTHER 56 K33



DRUM BIPUMP 12V



### PACKAGING

CODE		WEIGHT		PACKAGING		
WITHOUT METER	WITH METER	KG	LBS	MM	INCH	PCS/BOX
OO0271P00	OO0272P00	13,5	29,8	480X370X265	18,3X14,6X10,4	1
OO0273P00	OO0274P00	14,4	31,7	480X370X265	18,3X14,6X10,4	1
-	FO022205A	20,7	45,6	480X370X265	18,3X14,6X10,4	1
-	FO022206A	20,7	45,6	480X370X265	18,3X14,6X10,4	1
-	FO022207A	21,6	47,6	480X370X265	18,3X14,6X10,4	1
-	FO022208A	21,6	47,6	480X370X265	18,3X14,6X10,4	1
-	FO034111C	14,7	31,7	480X370X265	18,3X14,6X10,4	1



FILTRATION



TANK MONITORING



HOSE REEL



ACCESSORIES



MERCHANDISE

# PIUSI

BIS

ANY BIODIESEL

A

AIR

A

ANTIFREEZE

Ad

AdBlue®

B

BIODIESEL

D

DIESEL

F

FOOD

G

GASOLINE

G

GREASE

K

KEROSENE

O

OIL

W

WATER

W

WINDSCREEN

## CHART

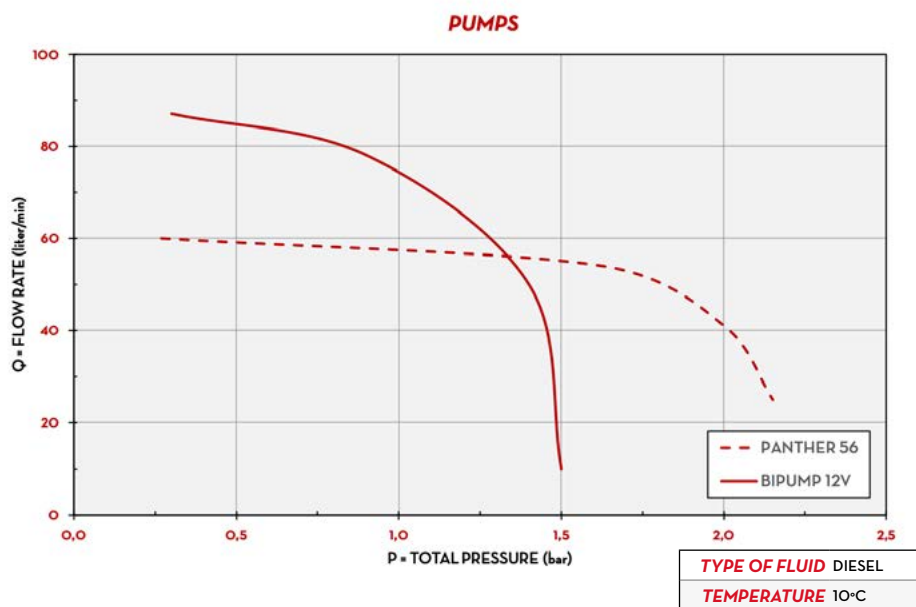

## IN THE BOX

- PUMP
- TELESCOPIC SUCTION PIPE
- DELIVERY HOSE
- NOZZLE
- 2" CONNECTOR
- K33 MECHANICAL METER (ON REQUEST)
- INSTRUCTION MANUAL

## DETAILS



2" CONNECTOR



TELESCOPIC SUCTION HOSE



ELECTRIC CABLE WITH CLAMPS (ONLY DC VERSION)

## COMPONENTS

- **PUMPS:**  
PANTHER AC  
BIPUMP  
PANTHER DC
- **METER:**  
K33

## DIMENSIONS

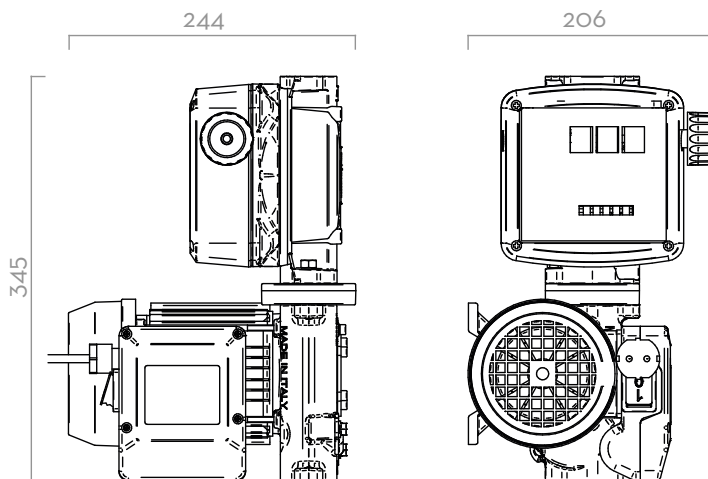

Dimensions expressed in millimeters

## TECHNICAL DATA

CODE		DESCRIPTION	FLUIDS TYPE	FLOW RATE		VOLTAGE			METER	NOZZLE	INLET	HOSE
WITHOUT METER	WITH METER			L/MIN	GPM	AC V./HZ DC VOLT	POWER WATT	AMP. MAX.				
000271POO	000272POO	DRUM PANTHER 56	D	56	15	230/50	350	3	K33	SELF2000	3/4"	4M
000273POO	000274POO	DRUM PANTHER 56 A60	D	56	15	230/50	350	3	K33	A60	3/4"	4M
-	FO022205A	DRUM BIPUMP 12V	D	80	21	12V	530	44	K33	SELF2000	1"	4M
-	FO022206A	DRUM BIPUMP 24V	D	80	21	24V	540	22,5	K33	SELF2000	1"	4M
-	FO022207A	DRUM BIPUMP 12V A120	D	80	21	12V	530	44	K33	A120	1"	4M
-	FO022208A	DRUM BIPUMP 24V A120	D	80	21	24V	540	22,5	K33	A120	1"	4M
-	FO03411IC	DRUM PANTHER DC 24/12V K33 A60	D	56	15	24/12V	420/150	25/16A	K33	A60	3/4"	4M