



SV SEWAGE PUMPS



- Liquid temperature : 0~40°C / 32~104°F
- HP range : 1/5~2HP / 0.15~1.5KW
- PH : 6~8
- Rated Speed : 2900 / 3450 rpm
- Protection class : IP68
- Maximum depth : 8M

Features

- 1 · Non-clogging vortex impeller.
- 2 · Suspended impeller and high efficacy flow channel design, no blocking. The pass solid is 40mm.

Applications

- 1 · Industrial sewage discharge
- 2 · Sewage and wastewater discharge

Sectional View

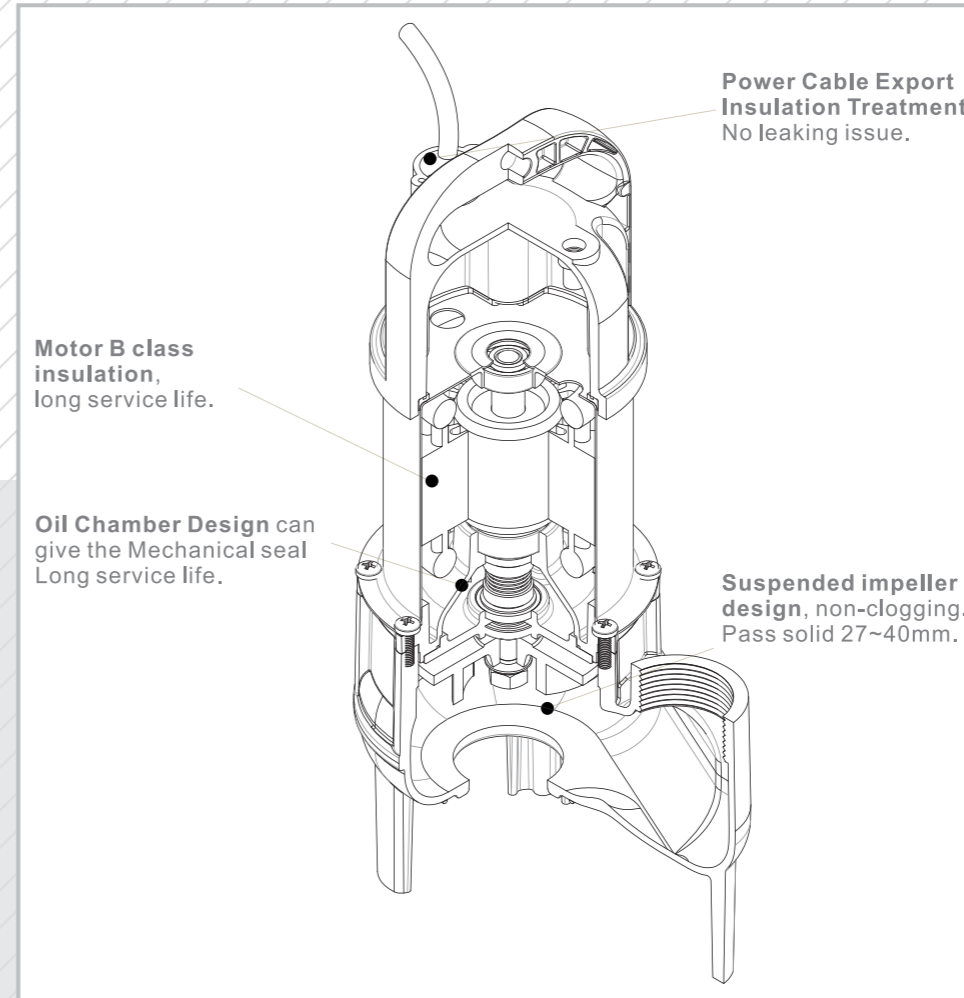

Curve

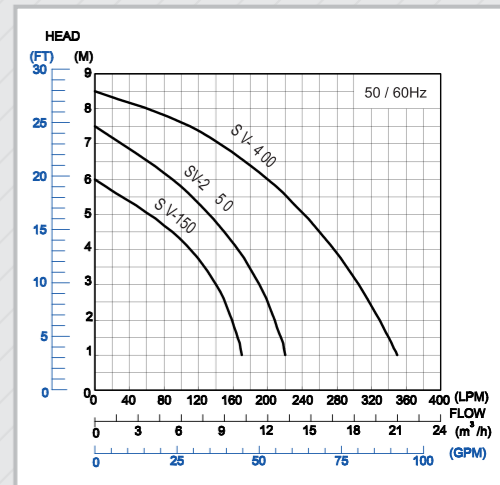
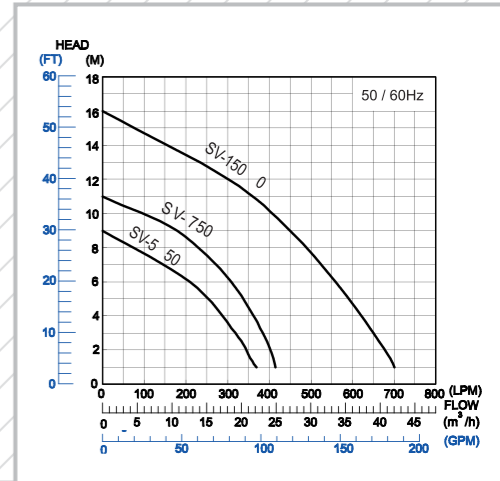

Standard Accessories

Model No.	Accessories
SV-150	Flange, Hose connection
SV-250	Flange, Hose connection
SV-400	Flange, Hose connection
SV-550	Flange, Hose connection
SV-750	Flange, Hose connection
SV-1500	Flange, Hose connection



Specification

Model No.	Output		Outlet		Pass Solid Dia(mm)	Max Flow(LPM)	LPM Flow @ Head					Max Head(M)	Dimension		Weight Kg
	HP	W	mm	inch			1.5M	3M	4.5M	6M	7.5M		L x W x H(mm)		
SV-150	1/5	150	40	1-1/2"	27	170	165	140	90	-	-	6	415 x 155 x 210	8	
SV-250	1/3	250	40	1-1/2"	27	220	215	190	150	90	-	7.5	415 x 155 x 210	9	
SV-400	1/2	400	50	2"	35	350	340	305	260	200	110	8.5	435 x 155 x 240	11	

Model No.	Output		Outlet		Pass Solid Dia(mm)	Max Flow(LPM)	LPM Flow @ Head					Max Head(M)	Dimension		Weight Kg
	HP	W	mm	inch			1.5M	3M	6M	9M	12M		L x W x H(mm)		
SV-550	3/4	550	80	3"	35	370	355	320	210	-	-	9	435 x 155 x 260	17	
SV-750	1	750	80	3"	37	415	410	385	310	180	-	11	435 x 155 x 260	18	
SV-1500	2	1500	80	3"	40	700	690	650	560	450	300	16	610 x 270 x 350	31	

Dimension

Model	Dimension									
	L	W	W1	W2	H	H1	H2	H3	H4	G
SV-150	196	140	83	108	380	220	99	99	124	1.5
SV-250	196	140	83	108	380	220	99	99	124	1.5
SV-400	210	157	83	108	395	240	113	113	138	2
SV-550	260	165	117	141	426	250	115	103	130	2
SV-750	260	165	117	141	460	260	115	103	130	3
SV-1500	310	200	117	141	560	350	142	142	170	3

