



SR

RESIDUE DEWATERING PUMP



- Liquid temperature : 0~40°C / 32~104°F
- HP range : 1/2HP /400W
- PH : 6~8
- Rated Speed : 2900 / 3450 rpm
- Protection class : IP68
- Maximum depth : 8M

Features

1. Ultra low residual water(1mm).
2. On the outlet design, can be applied to low water level environment.

Applications

1. Ultra-low residual water exclusion environment (clean water)

Dimension

Dimension					
Model	L	H	H1	H2	G
	mm	mm	mm	mm	inch
SR-400	205	328	53	2.5	2

Curve

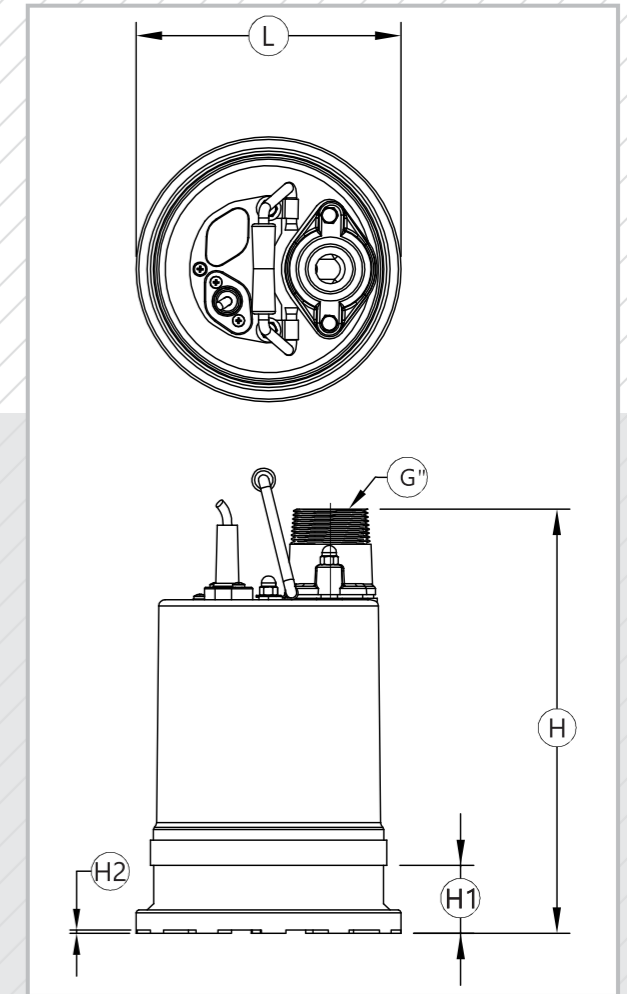
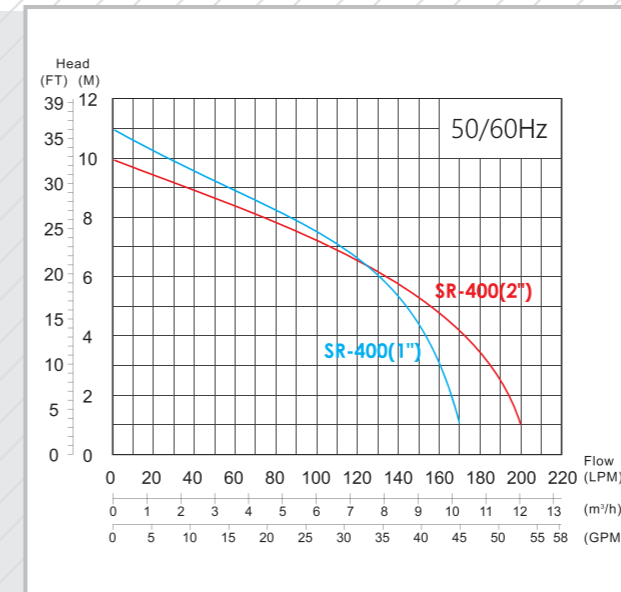

Specification

Model No.	Output		Outlet		Pass Solid Dia(mm)	Max Flow (LPM)	LPM Flow @ Head					Max Head(M)	Dimension		Weight Kg
	HP	W	mm	inch			1.5M	3M	4.5M	6M	7.5M		L x W x H(mm)		
SR-400 1"	1/2	400	25	1"	7	170	165	160	150	130	100	11	181 x 181 x 340	16	
SR-400 2"	1/2	400	50	2"	7	200	195	185	165	135	90	10	181 x 181 x 340	16	

Standard Accessories

Model No.	Accessories
SR-400 1"	Flange with male thread
SR-400 2"	Flange with male thread

