



SD SEWAGE PUMPS



- Liquid temperature : 0~40°C / 32~104°F
- HP range : 1/3~1HP / 250~750W
- PH : 6~8
- Rated Speed : 2900 / 3450 rpm
- Protection class : IP68
- Maximum depth : 8M

Features

1. Cooling motor design, 24 hours operation.
2. Drain out the water from the top can be used in low water environment.

Applications

1. Industrial sewage discharge

Dimension

Model	Dimension				
	L	H	H1	H2	G
	mm	mm	mm	mm	inch
SD-250	183	326	256	49	2
SD-400	183	326	256	49	2
SD-750	183	343	273	49	2

Curve

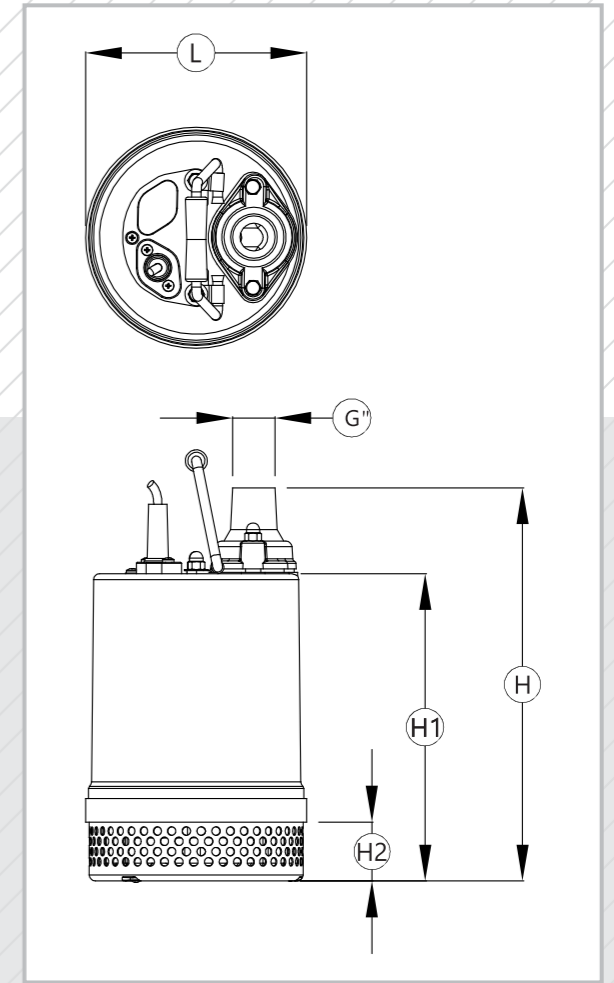
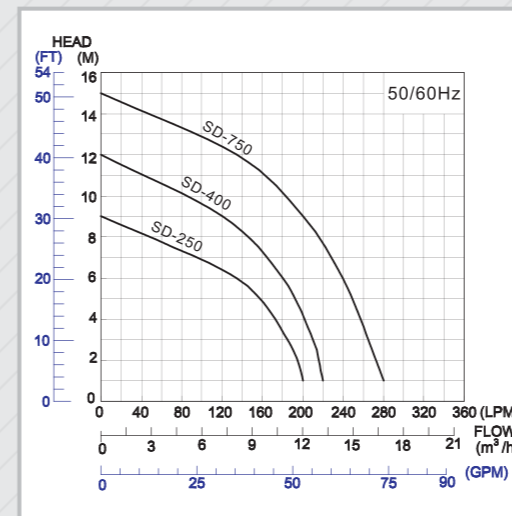

Specification

Model No.	Output		Outlet		Pass Solid Dia(mm)	Max Flow (LPM)	LPM Flow @ Head					Max Head(M)	Dimension	Weight Kg
	HP	W	mm	inch			1.5M	3M	6M	9M	12M		L x W x H(mm)	
SD-250	1/3	250	50	2"	7	220	215	197	130	-	-	9	181 x 181 x 340	12
SD-400	1/2	400	50	2"	7	240	237	225	180	100	-	11	181 x 181 x 340	12
SD-750	1	750	50	2"	7	300	295	280	240	185	110	15	181 x 181 x 343	15

Remarks: Model No. ends with "A" is equipped with float switch.

Standard Accessories

Model No.	Accessories
SD-250	Flange with male thread
SD-400	Flange with male thread
SD-750	Flange with male thread

