

JETHYDRO®

Cutting through Innovation

HURRICANE™+

DRAIN CLEANER RANGE

PSI
4400 - 5080

L/PM
25 - 36.4

ENGINE TYPE
V - TWIN EFI PETROL
33 - 37HP

 ENGLISH
VERSION

JETWAVEGROUP.COM



VANGUARD
COMMERCIAL POWER
GRIGGS & STRATTON

VANGUARD
EFI
ELECTRONIC FUEL INJECTION



HURRICANE™ +

The Jetwave Hurricane range revolutionises the petrol v-twin driven water jetting machine. Australian engineered and assembled; its innovation provides plumbers with a compact powerful, safe and easy to use unit that encompasses world first technology an all new Stainless Steel Exoskeleton (PEXO™) & multi-configurable design. This is the NEW Hurricane family from Jetwave.

HERO INNOVATIONS



Stainless Steel Exoskeleton (PEXO™)



JRS400 Smartjet Remote Control System



Centralised control for safety and effectiveness



Anti-vibration Protection System (AVPS™)



JW™ Premium Italian pumps.



InteliUMS LCD control centre with digital live read outs of parameters.

MAIN FEATURES

Vanguard EFI Engines

InteliUMS LCD Control

Slow speed pump

Large on-board water tank

JW™ Triplex Italian pump

Professional nozzle kit

FIELDS OF APPLICATION

Plumbing businesses & contractors

Tree roots and debris removal

Grease, sludge & dirt removal

Municipality contractors

State and local council

A revolutionary high velocity pressure jetting solution

Jethydro is a brand created and powered by Jetwave Group in a bid to cater for the jetting industry. Drawing upon Jetwave's 30 years expertise, Jethydro was born in conjunction with plumbing professionals.

Innovation isn't just making something different, it's making it safer, easier, faster, more practical and efficient than ever. This cutting edge product is made specifically for plumbers. It has been designed, developed, manufactured and quality assured by a specialist team; passionate to provide the next step in water jetting equipment innovation and evolution. Why? Because we knew things could be better.

Because perception of your service starts with how your equipment looks we invest time and money into attractive, functional, automotive inspired design.

Through a turn key, out of the box solution, that you spec your way. This enhanced solutions contribute to building your business through better tools. Equipment that is functional and technologically advanced to the point that its reliable day in and day out.

We aim to add more value than ever before and we guarantee a smoother application, specific installation and operational life that will yield increased return on your investment and contribute to grow your business in the area of plumbing pipe/drain maintenance blockage clearing.

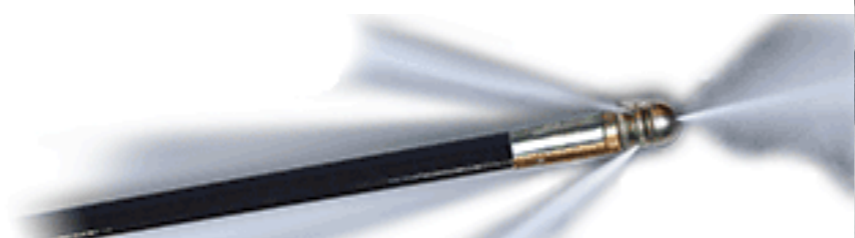

PVC Pipes



Sewer Lines

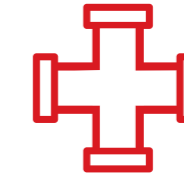

Branch Sewer Lines



Stormwater Pipes



Roof Drains



Shower Stalls



Yard & Lot Drains



Floor Drains



We are here to meet your water jetting needs with a product categorically developed for the professional plumber.

WHAT

A product that embodies the most innovative and technological evolution in design and performance for plumbers to utilise in their drain cleaning maintenance business, to leverage and create versatility in an all-in-one configurable solution fit for your exact application.

HOW

This is a bid to decrease your need for fabrication customisation, installation time, vehicle configuration flexibility and to clear blockages quicker. To increase business efficiency that will deliver you more time and money.

Registered Design No.: 201710299

WHY

Why use water jetting over traditional methods of drain cleaning? This method has rapidly grown over the past several years and in the past manufacturers have adapted other equipment to meet market demands, as mix of operator friendliness, safety, performance and technology had yet to be developed for this market and optimised for users needs.

A water jet sends highly pressurised water through a nozzle at the end of a hose, which is inserted into the drain pipe line. The JetHydro range provides an array of exotic nozzles to suit different blockages.

JetHydro offers more versatility for cutting and flushing through blockages. It is safer due to its design and proper component selection built from the ground up, water jetting is typically more effective, and less strenuous. All the while power scrubbing and scouring the inside of the pipeline to near new condition.

These water jetting machines are outstanding for heavy-duty cutting and flushing jobs such as:

- Tree root intrusion
- Storm water
- Fat, oil & grease
- Sand
- Sediment & dirt
- Soap
- Leaves
- Paper

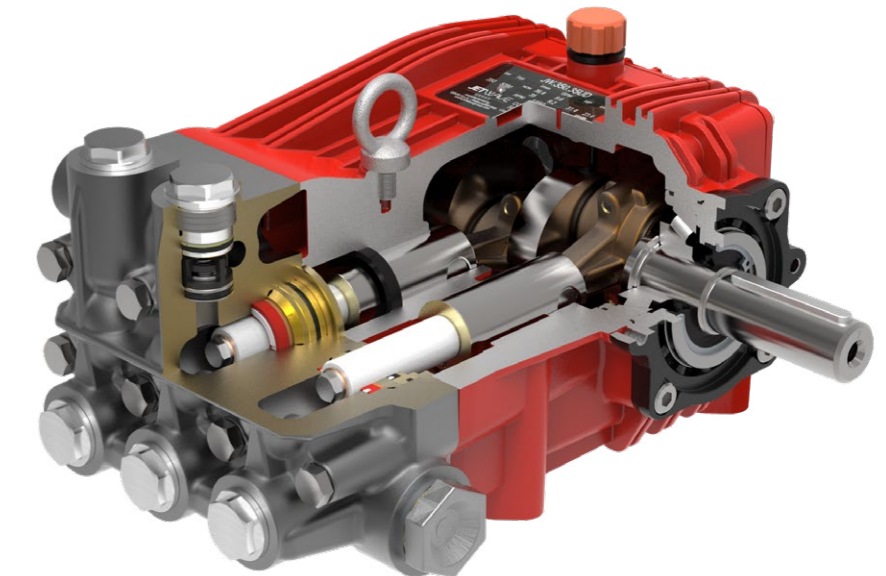



Residential



Homeowners will see investment with your professional specialised machinery. Add a specialist service and contribute to your businesses improved charge out rates.

Industrial



Heavy industry can produce some heavy duty waste. You need the most powerful, effective and efficient equipment to provide scope for your pipe/drain cleaning business.

Commercial



From the local bakery to the largest commercial office buildings, JetHydro gets the job done powerfully so you can win more jobs and get back to more business.

Municipal



Municipal sewer, pipe and drain cleaning. This will provide the scope to spec up or down depending on application. We aim to provide you more versatility to tender and win jobs with cost effective investment into equipment and available options.

HURRICANE™+

A decisive step into the future of water jetting technology with a product categorically developed for a mid-tier domestic / commercial pipe cleaning professional.

JetHydro dramatically improves and revolutionises the most significant aspects of a water jetting machine, and the overall experience.

It introduces innovative never seen before technology and capability on a jetting systems. The best performance, technology integration and life protection ever in such machinery. A range of endless mounting possibilities. Unified, smart LED digital display with unit protection parameters.

A formed steel covers provide protection from the elements for the life of your investment with adaptive EFI engine and auto speed technology optimisation. It looks every bit as powerfully cutting edge as it is.

This is JetHydro.



HURRICANE PRODUCT VIDEO

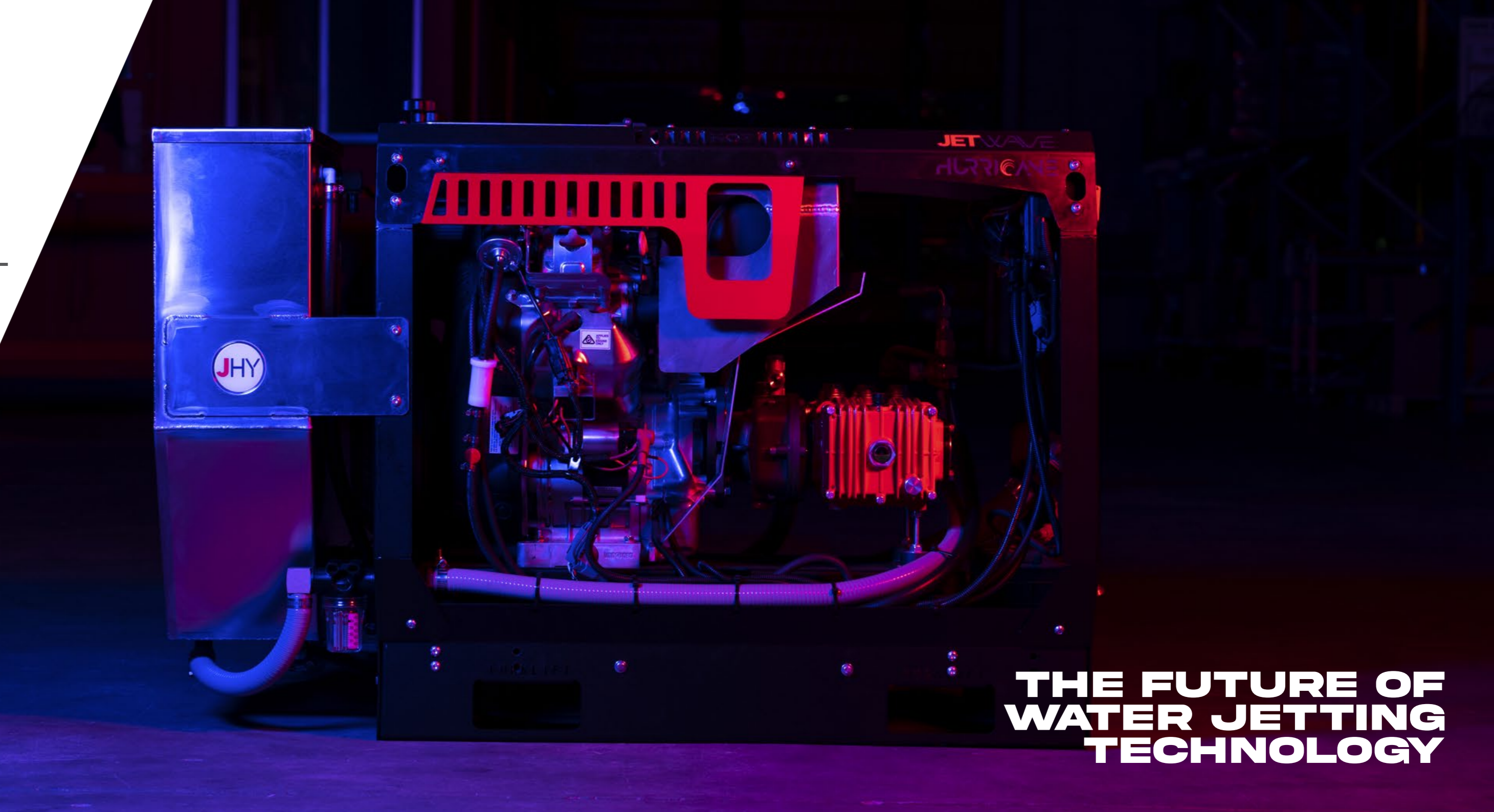

**THE FUTURE OF
WATER JETTING
TECHNOLOGY**



HERO INNOVATION

STAINLESS STEEL

EXOSKELETON

HERO INNOVATIONS



STAINLESS STEEL EXOSKELETON (PEXO™)



STAINLESS STEEL EXOSKELETON VIDEO

PROTECTION & SAFETY

The industrial precision CNC formed Stainless Steel exoskeleton provides enduring protection to the entire machine and importantly its critical working components protecting it from harsh outdoor weather elements and on site overspray.

BENEFITS

- 01 Compact space saving design.
- 02 Unit and operator safety maximised.
- 03 Made of heavy duty formed stainless steel.
- 04 New attractive and aesthetic design.
- 05 All critical components are still reachable for maintenance / minor repair operation.
- 06 Longer working life of your investment.
- 07 Increases reliability.
- 08 Mitigates risk of down time.
- 09 Easy removable cover for serviceability and maintenance checks.
- 10 Extend maintenance intervals.
- 11 Increased worksite safety.

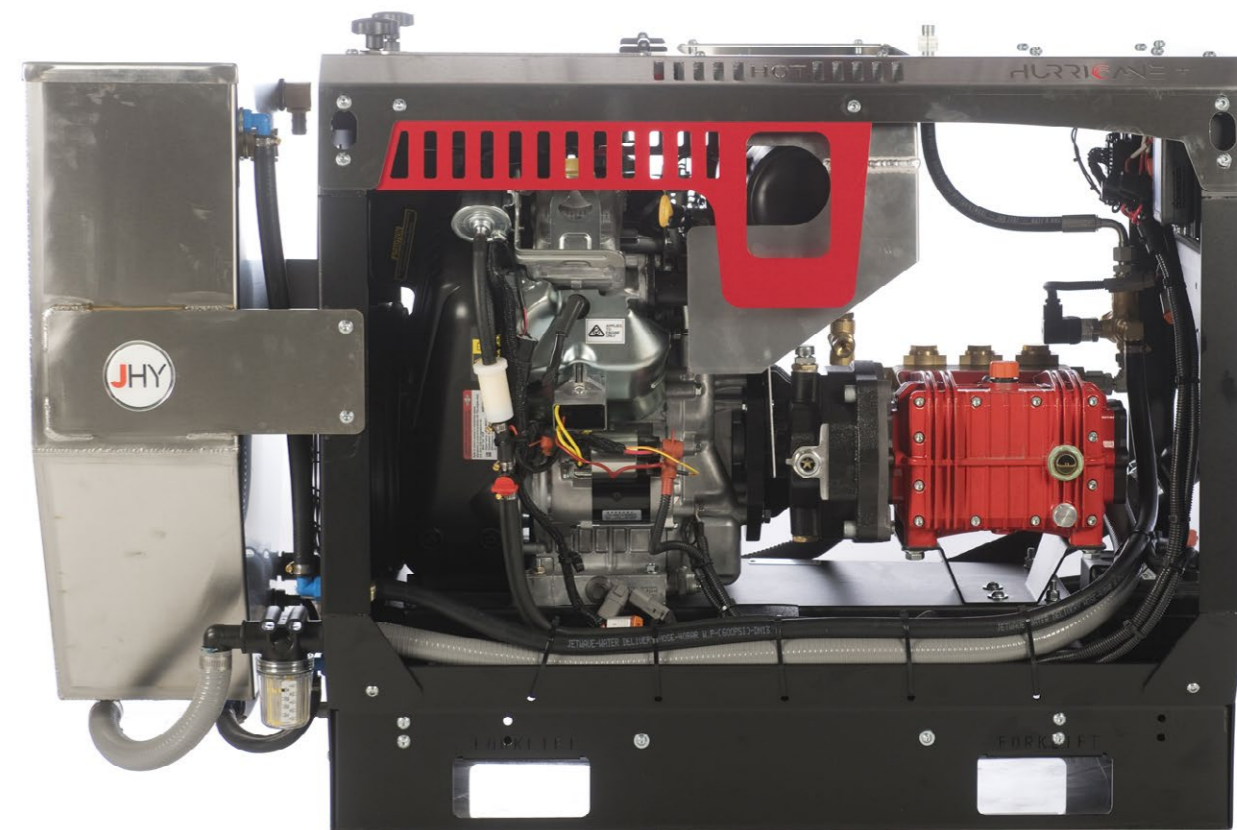



INTELIUMS™



INTELIUMS™ VIDEO

DIGITAL, ACCURATE & INTUITIVE

This smart, industry first, IntelliUMS™ is the brains of the Hurricane control centre. This LCD backlit screen provides integrated operator control, monitoring and protection for both the unit's mechanical and electrical at all times.

This new high tech protection and monitoring interface allows you to fully control and monitor the machines vital signs accurately and in real time. It displays all performance data and warning alerts on a digital display that delivers unit data to continuously optimise the working parameters and the operators experience and safeguard your investment.

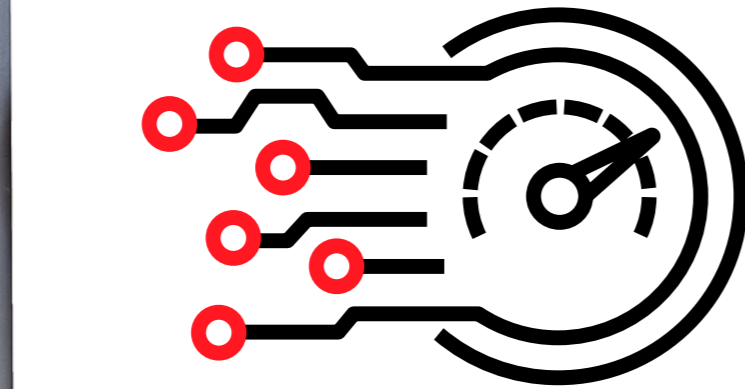

BENEFITS

- 1 Key less Start / Stop.
- 02 Easy chokeless starting.
- 03 Displays all performance data such as:
 - Battery voltage
 - Running hour meter
 - Pump working pressure
 - RPM tachometer
- 04 Warning alarm set points:
 - Service interval reminders
 - High temperature
 - Oil pressure
 - Low fuel level warning
 - Battery flat detection
 - Load governance
- Over pressurisation alert
- Operational speed
- Over-cranking protection
- Error log
- 05 No push or pull manual leavers / toggles.
- 06 Large LCD back-lit display screen.
- 07 'Zero' power consumption mode screen.
- 08 Safeguards your investment to mitigate the risk careless operator error or misuse.
- 09 IP65 dust and water protection.



CENTRALISED CONTROL



CENTRALISED CONTROL VIDEO

VERSATILE & EFFECTIVE

Front facing and panel mounted controls for easy accessibility to all controls and adjustment components that ensure that equipment delivers correctly and to adapt to your jetting job at hand in order to maximise blockage clearing efficiency, effectiveness and operator friendliness.

BENEFITS

- 01 Simplicity of a functional centralised control centre.
- 02 Safety emergency stop button.
- 03 Key battery isolator.
- 04 12v axillary power outlet socket.
- 05 Easy and ergonomic fuel fill.
- 06 Ensure safety and prevent unauthorised access.
- 07 Save time with controls that are easily reachable and clearly indicated.
- 08 IntelliUMS™ LCD digital control display screen.
- 9 Panel mounted lead hose / plug connections.
- 10 Plug & play connections for integrated and external low level water cut-out pump protection.
- 11 Protected recessed controls.





AUTO-SPEED TECHNOLOGY (AST™)



AUTO SPEED TECH VIDEO



LOWER SOUND LEVELS

Auto-speed technology, a Jetwave exclusive, provides a link from pump to engine, in effect when jetting is not taking place the engine will decrease to idle RPM speed and back up to optimal RPM full speed to achieve working pressure and flow for the pressure cleaning process. Allowing you to get more out of your equipment putting it to work for longer ultimately effecting positively your bottom line.

BENEFITS

- 01 Optimises engine speeds to load.
- 02 Significantly extended run times.
- 03 Decreases fuel consumption.
- 04 Drastically decreased noise levels.
- 05 Less RPMs equals less maintenance costs.
- 06 Reduces emissions and exhaust gases.
- 07 Allows you to work day and night.
- 08 Fewer refueling trips.
- 09 Deliver maximum runtime.

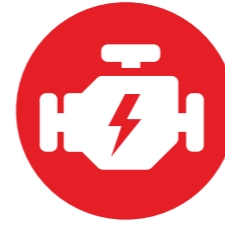
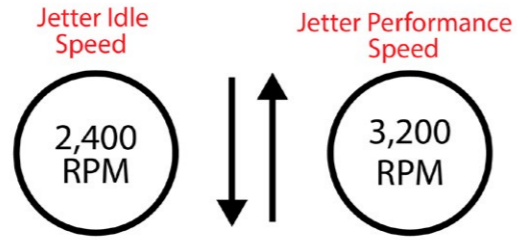

EFI ENGINE

OPTIMISED & EFFICIENT

The BIG BLOCK™ V-Twin petrol engine delivers some of the best power, performance and reliability in its class. With its automotive style EFI closed loop technology it optimises all engine speeds and loads.

BENEFITS

- 01 Yields a 25% decrease in fuel consumption (multiplies with auto-speed technology).
- 02 Quieter operation.
- 03 Save on running and maintenance costs.
- 04 Meets global emission compliance.
- 05 Environmentally friendly option.
- 06 Easy start with air fuel altitude compensation.
- 07 Global parts availability and back-up service network.
- 08 Matched pump to engine load.
- 09 Exclusive flat style air cleaner for more compactness.
- 10 Improved state fuel resistance.

UP TO **25%** MORE FUEL EFFICIENT

CARBURETED MODELS
15 HOURS OF RUNTIME

+5 HOURS

JetHydro with EFI & AST™
20 HOURS OF RUNTIME

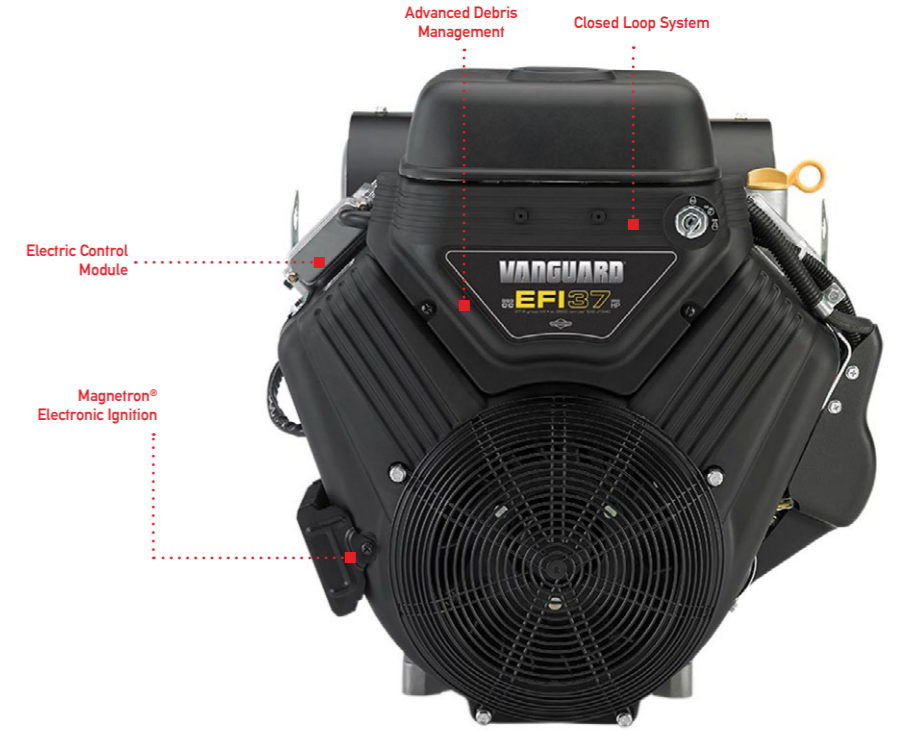

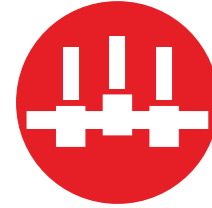

JW PREMIUM PUMPS



JW PREMIUM PUMPS VIDEO

LOW MAINTENANCE & HIGH EFFICIENCY

The finest quality Italian raw materials are used in the newly developed JW Premium Pump range, it redefines the benchmark of quality. Designed in close cooperation with the ISO9001 research & development department of one of the world's largest plunger pump manufacturers, this pump series is packed with exclusive innovative solutions to improve pump performance, reliability and longer life.

This new premium pump range guarantees the highest levels of reliability on the market even in the harshest of working conditions.

BENEFITS

- 1 NEW overall enhanced efficiency and aesthetic performance pump design.
- 2 NEW Extended/oversized rear crankcase to reduce oil temperatures and to run cooler for longer.
- 3 'Ni' Nickel treated brass forged manifold for anti-corrosion, and better resistance to fatigue (selected models)
- 4 Magnetic oil drain plug to attract all microscopic material.
- 5 Red powder coated die cast aluminum crank case. Resulting in MORE Corrosion resistance.
- 6 Unique blended NBR seals for a longer life in heavy duty application.

- 7 Dust cover for seal protection in dirty environment.
- 8 Glass fibre impregnated valve cages for higher temperature resistance
- 9 Oversized Plunger guide with 'step' diameter for longer seal life.
- 10 Large, easily visible oil level sight glass.
- 11 Oversized two piece Bronze Conrods (selected models) in special low friction bronze alloy to improve load distribution.
- 12 Premium quality bearings, for lower friction to ensure lower operating temperatures.
- 13 Teflon based gasket on rear cover to ensure better sealing at high oil temperature.
- 14 Extra thick solid ceramic pistons for greater durability to wear & thermal shock.
- 15 Stainless steel high volumetric efficiency inlet & delivery valves for greater cleaning performance

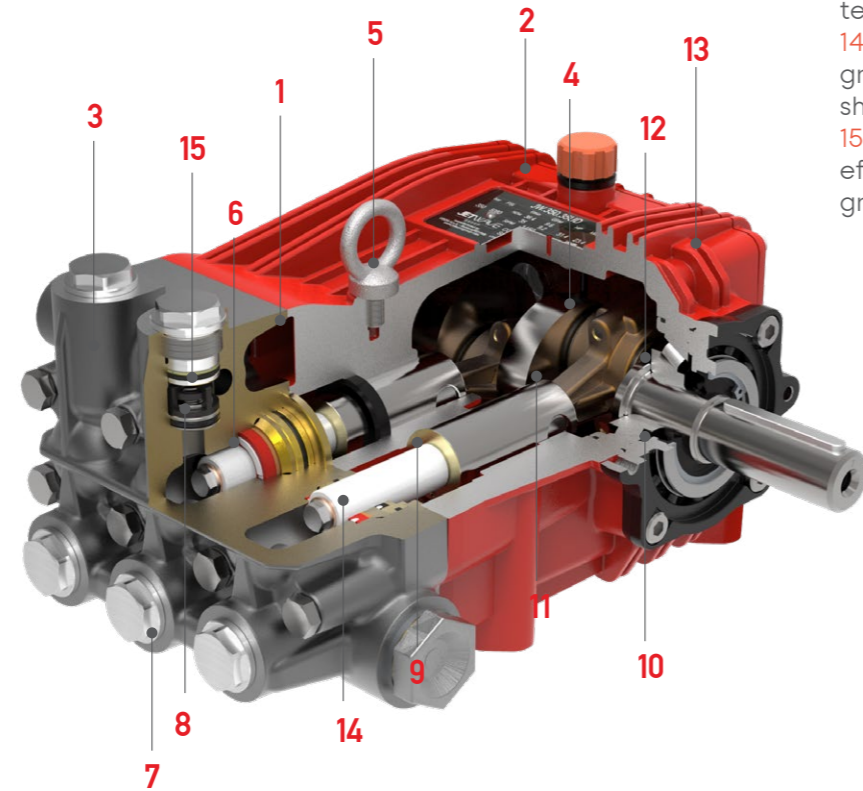

JETWAVE
PUMPS

MANUFACTURED IN COOPERATION WITH

UDOR
WATER POWER



JRS400 SMARTJET™ REMOTE SYSTEM

SAFETY & CONVENIENCE

Introducing the JRS400 SmartJet remote system that comes standard on all Hurricane models. With an industrial remote in a heavy duty case this allows operators to remotely control their Hurricane water jetter. This then contributes to a safer worksite & more flexible water jetting operation for plumbers.

BENEFITS

- 01 Heavy duty remote control.
- 02 Up to 100m range.
- 03 IP65 Water resistant.
- 04 Close & open ball valve at the machines high pressure outlet.
- 05 High temperature resistant.



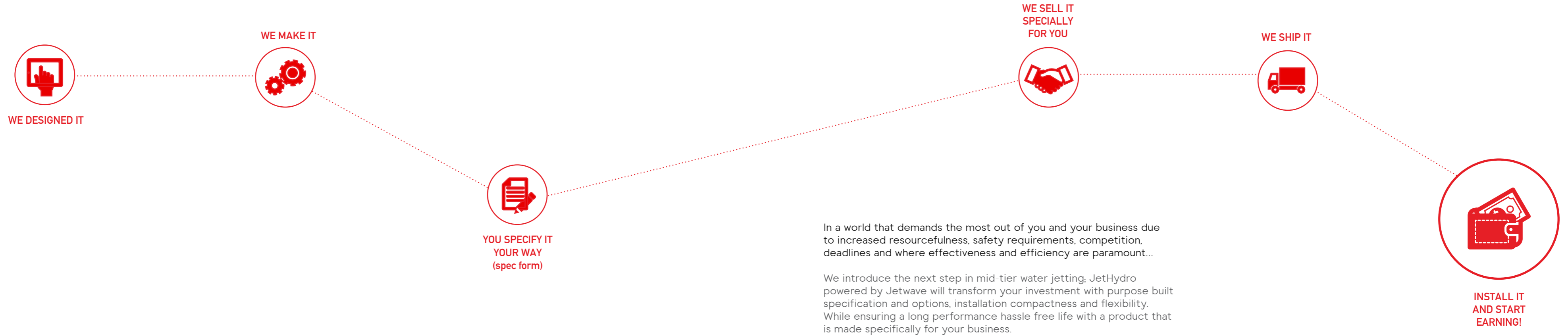

In a world that demands the most out of you and your business due to increased resourcefulness, safety requirements, competition, deadlines and where effectiveness and efficiency are paramount...

We introduce the next step in mid-tier water jetting; JetHydro powered by Jetwave will transform your investment with purpose built specification and options, installation compactness and flexibility. While ensuring a long performance hassle free life with a product that is made specifically for your business.

Empowering you with new possibilities to grow and diversify your plumbing business.

60M VIPERFLEX
Best in class hose.

EFI ENGINE
Oversized Cutting Edge Stationary Engine with EFI Technology from a global manufacturer, to assist with putting you ahead of the competition and maximise unit efficiency.

PUMP, GEARBOX AND COMPONENTS
The highest quality precision Italian manufactured components with enormous flow and pressure performance for the toughest blockages.

INTELLIUMS™
Functional easy read LED backlit for unit data and monitoring protection and operator control.

CENTRALISED CONTROL FASCIA PANEL
All unit controls ergonomically placed front facing for maximum mounting versatility and operator comfort.

FRAME STRUCTURE
Modular and compact precision CNC design.

100M CAPACITY HOSE REEL
High quality extra heavy duty reel built to last with double ball bearing support precision, welded hub and hi-flow stainless steel swivel; in-built drag break and multi-point locking pin.

STAINLESS STEEL EXOSKELETON (PEXO)
Sturdy industrial formed cover protection for durability and enduring component protection for the life of your investment

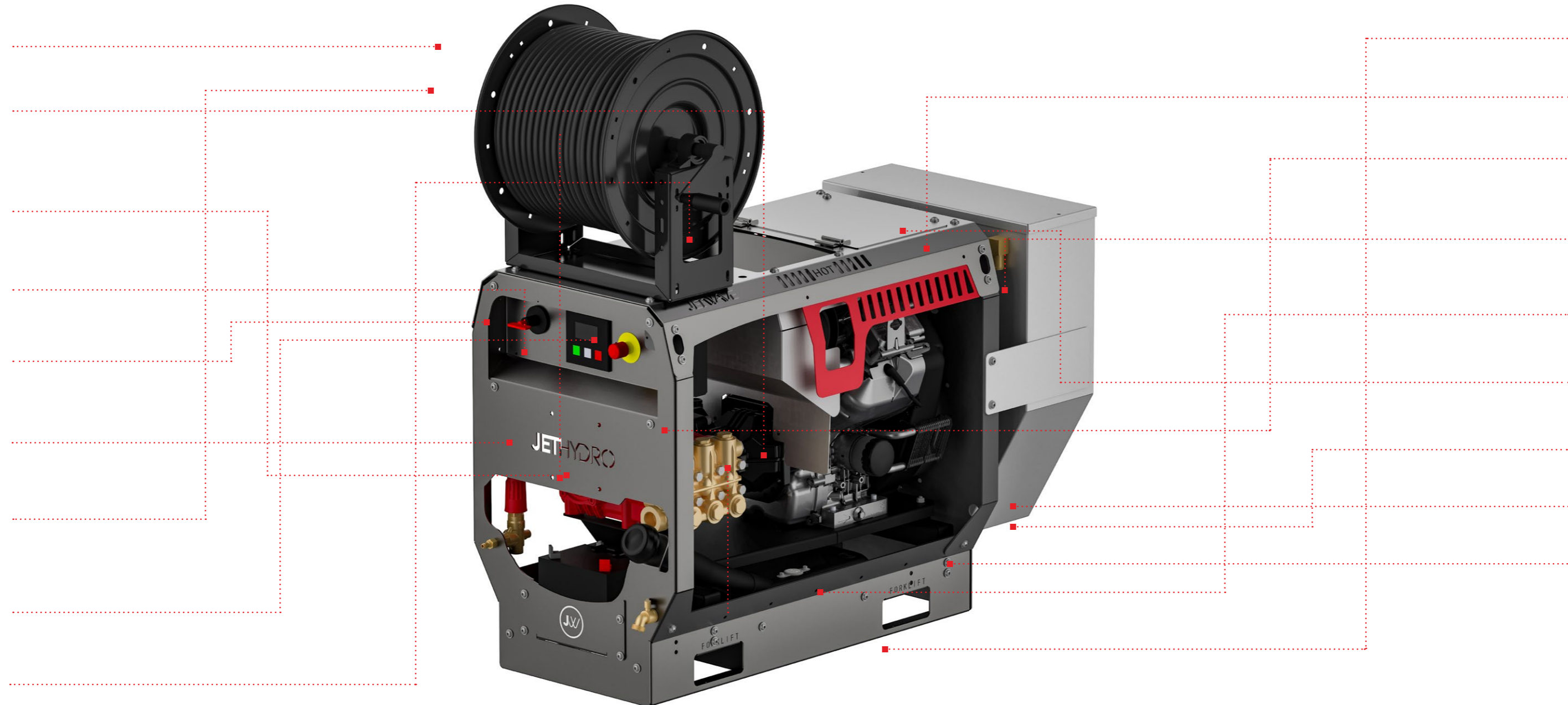

FORKLIFT/MOUNTING INTEGRATED POCKETS
Easy transportation via forklift around on-site.

HIGH/LOW PRESSURE OUTLETS
External panel mounted for plug+play connections.

SAFETY VALVE
Compliant and set valve to prevent pressure spikes and damage to the pump.

WATER TANK
High quality, sturdy and large capacity with a high flow float valve system. Detachable for water cartage tank feed / larger capacity.

ANTI-VIBRATION SYSTEM (AVPS)
This boasts life expectancy and ensures a longer, quieter unit performance.

LOW LEVEL WATER CUT OUT
To ensure pump anti-run dry protection at all times.

HEAVY DUTY
Washable in-line gauze water filter.

JRS400 SMARTJET REMOTE START / STOP
Heavy duty industrial remote control for more flexible jetting operation.

PAYBACKS IN INNOVATION YOU CAN TAKE TO THE BANK

Operator safety and functionality greater than ever before.

Reduce expenses and downtime.

Choice of performances 4400 - 5075 psi at 25 - 36.4 lpm.

Improve productivity and job site safety.

Increase runtime.

Optimise space via configurations, meaning more room in your van, truck or work trailer for other job site tools and equipment.

Decreased risk of operator error.

Maintenance costs squeezed.

Lower cost of ownership long term.
More environmentally friendly.

Product longevity.
Investment protected/stupid proof.

Jobs done faster, safer and more efficient.

Versatility across mounting/vehicle configurations to provide space savings.

Decreased noise levels:

- Less engine noise means clearer communication onsite.
- Can be used earlier and later in noise sensitive environment so more work can get done.

Maintain integrated unit monitoring for warning and performance data.



Seamlessly mount your way.

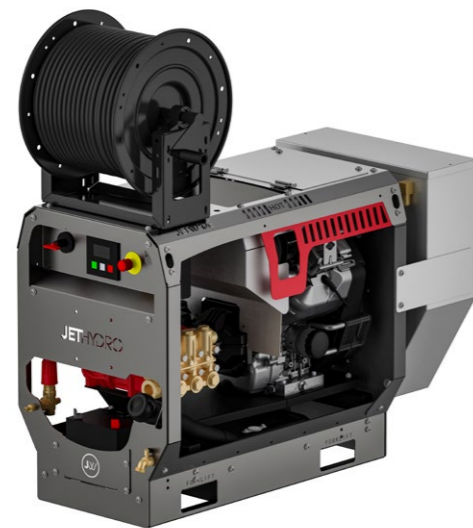

1.0 Skid - Standard

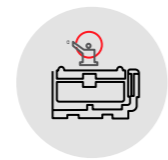

SKID MOUNT

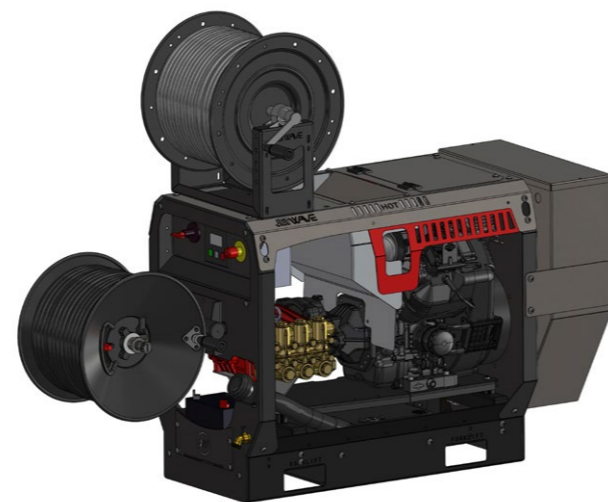

1.1 Skid - With Low Pressure Reel

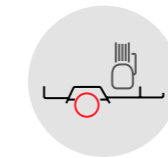

TRAILER MOUNT



2.0 Trailer - 200L Tank



UTE MOUNT



VAN MOUNT

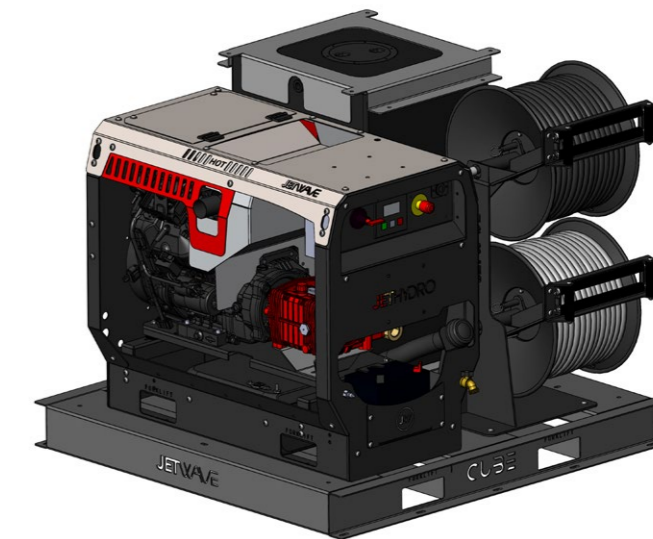

3.0 Cube - 200L Tank

APACHE PRIMARY REEL



100m Apache Primary Reel with 3/8" 60m Viperflex® hose. With safety restraint sock.

STAINLESS STEEL BYPASS TANK



50L Water bypass & feed tank.

PROFESSIONAL NOZZLE KIT



- 1 x Reverse Root Cutter
- 1 x Penetrator
- 1 x Negotiator
- 1 x Negotiator (small)
- 2 x Hard ABS Plastic Nozzle
- 1 x 1/4" Hose End (1 piece)
- 1 x 3/8" Hose End (1 piece)
- 1 x Multi-tool Spanner
- 1 x Nozzle Tip Cleaner
- 1 x Extension Bar
- 1 x Extra Heavy Duty Carry Case

SPRAY GUN & LANCE



Spray gun and lance.

LOW PRESSURE INLET REEL WITH 30M HOSE

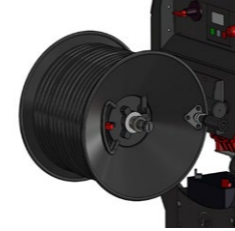

Hose reel mounted to the front of the unit with 30m of low pressure inlet hose.

EMERGENCY STOP & BATTERY ISOLATOR



For more onsite safety and to meet certain site safety standards.

LOW LEVEL WATER CUT OUT



Water tank cut out protection.

JRS400 SMART JET REMOTE CONTROL



For remote control of the Hurricane water jetter to allow a more safer worksite and better jetting operation.

REMOTE MINI REEL



Portable remote reel with 60m of 1/4" viperflox hose. Snap coupling, ball valve, pressure gauge and electroless polished stainless steel frame.

P/N: PW134-RRCMPL/HOP4
 LOCKING PLATE: P/N: 90012HRH-LP

FORWARD ROOT CUTTING NOZZLE

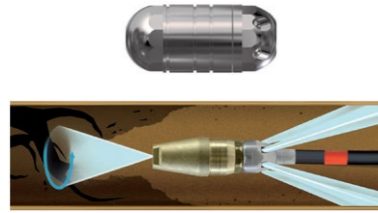

Forward root cutting nozzle.
 P/N: C43RS

15M VIPERFLEX FLEXIBLE WHIP HOSE



15m of 1/8" whip hose.
 P/N: HOP3VFX15-ASSY

APACHE A-FRAME HOSE REEL

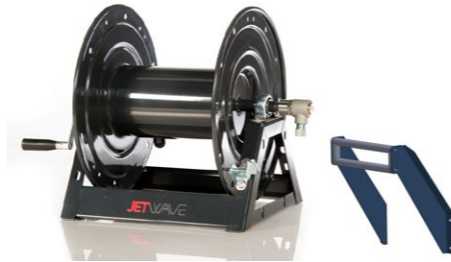

Apache A-Frame hose reel capacity of 120m (no hose included). Optional vertical or horizontal hose reel guides
 P/N: DHRA50300
 HOSE REEL GUIDES: P/N: 2100503/H

CLASS B DOUBLE ACTION FOOT VALVE

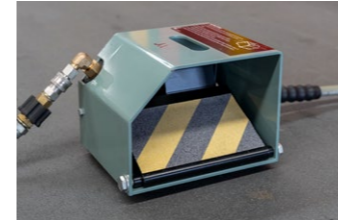

Adheres to Class B AZNS regulations, foot valve kit for hands free safe jetting control.
 P/N: 90171CMPL

PREMIUM DANGER SIGN



15m of 1/8" whip hose.
 P/N: JWA316

JETTING SAFETY PLATE

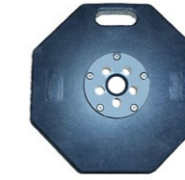

Jetting safety plate
 P/N: JSP

500 BAR TST PPE SAFETY PACK



Safety vest, pants, boots, coat, helmet, hearing and visor.
 P/N: TBA

DOUBLE STACKED APACHE HOSE REEL KIT



Double stacked 120m apache a-frame premium hose reels
 P/N: 2100437

APACHE 12V REWIND KIT



12v electronic rewind kit to suite apache hose reels.
 P/N: JWA420

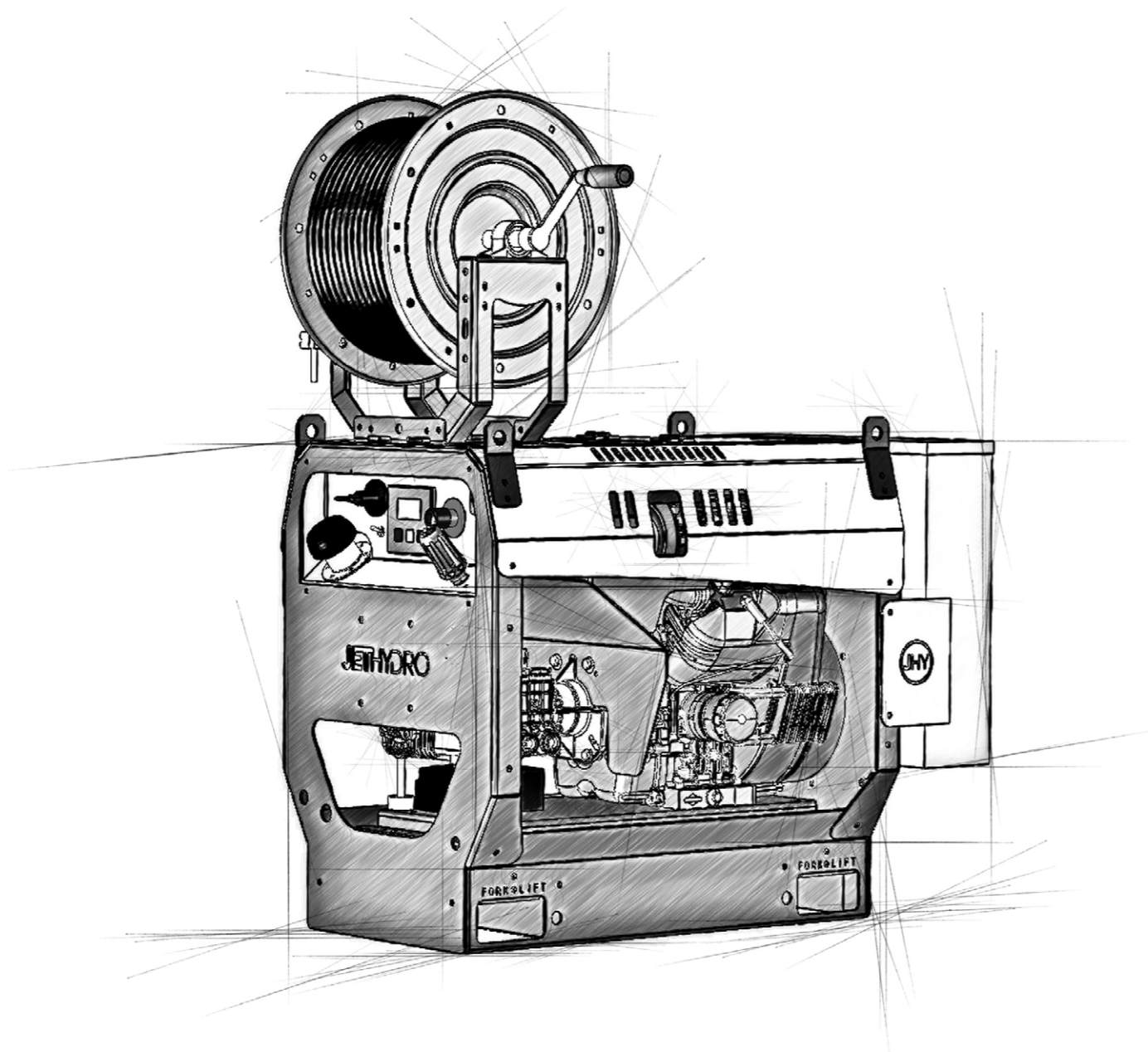

JetHydro represents better equipment for a better world. Our dedicated and passionate team aim to revolutionise the industry in which we operate in, therefore creating a professional value added product:

- To provide more results for your customers.
- Build job satisfaction and sustainability.
- Build your business by reducing expenses and adding to the bottom line.
- Build progress with better equipment for users contributing to a smarter, safer and more efficient world.

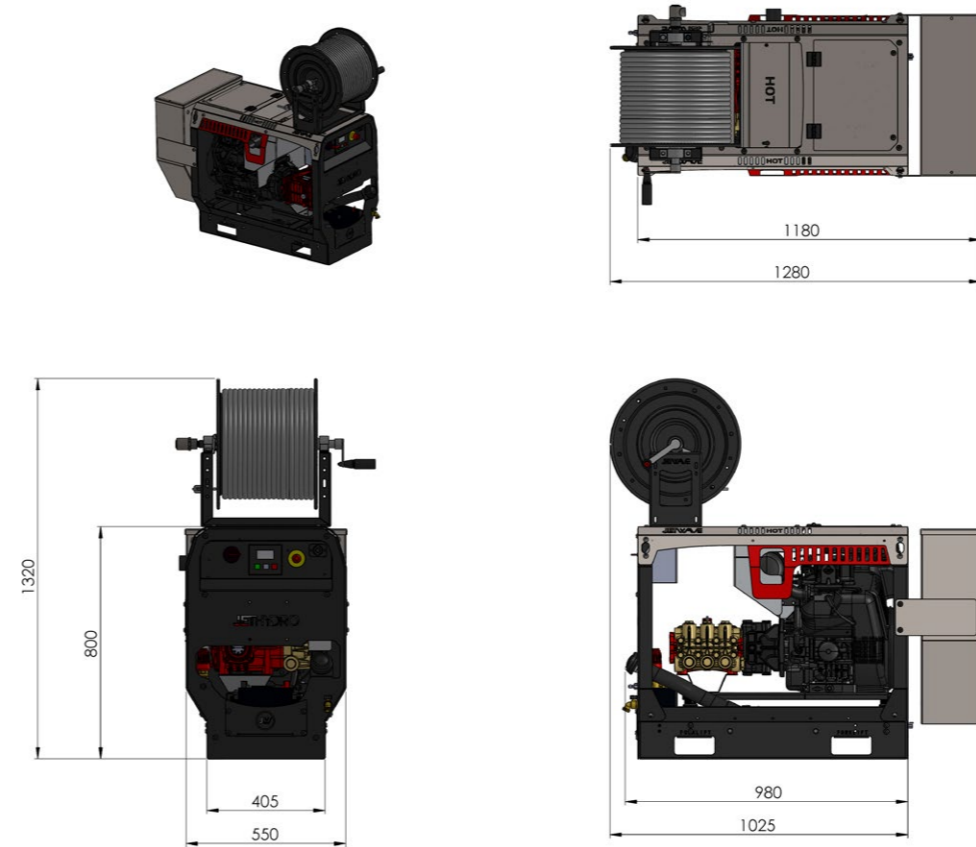

MOUNTING DATA

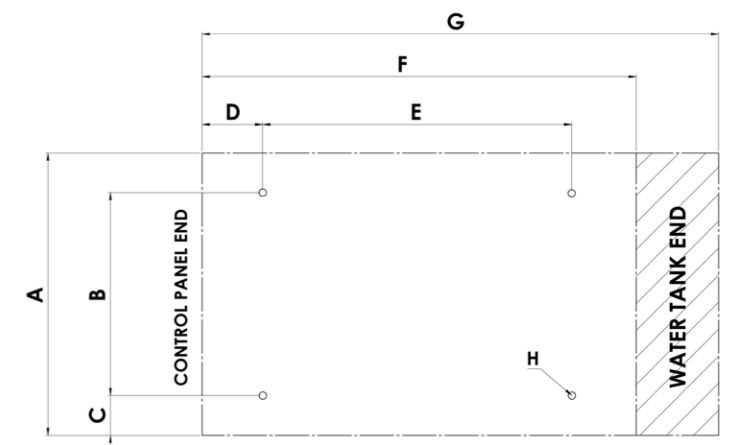

- A. 407mm
- B. 347mm
- C. 30mm
- D. 195mm
- E. 540mm
- F. 930mm
- G. 1180mm
- H. \varnothing 10mm

RANGE BUILD UP



HURRICANE



HURRICANE



HURRICANE+

Product Code	p/n	JH4400-33PB	JH5000-25PB	JH5000-36PB
TECHNICAL DATA				
Working Pressure	psi / bar	4400 / 300	5075 / 350	5080 / 350
Flow Rate	l/min	33	25	36.4
Max Inlet Temperature	°c / °f	60 / 140	60 / 140	60 / 140
Class (AS/NZS 4233.1:2013)	class	B (9,900 BAR/LITRES)	B (8,750 BAR/LITRES)	B (12,600 BAR/LITRES)
MOTOR/ELECTRICAL FEATURES				
Engine	type	VANGUARD BIGBLOCK (B&S)	VANGUARD BIGBLOCK (B&S)	VANGUARD BIGBLOCK (B&S)
Power	hp / cc	33 / 896	33 / 896	37 / 996
Engine Control Module	type	EFI	EFI	EFI
Unit Management System	type	InteliUMS™	InteliUMS™	InteliUMS™
Auto Speed Technology™	y / n	Y	Y	Y
Fuel supply	type	Unleaded	Unleaded	Unleaded
Fuel Capacity	litres	25 (with level gauge)	25 (with level gauge)	25 (with level gauge)
Low Oil Shutdown	y / n	Y	Y	Y
HYDRAULIC FEATURES				
Pump / Head / Pistons / Valves	type / material	JW® Triplex Plunger / Brass (Nickel Plated) / Ceramic	JW® Triplex Plunger / Brass (Nickel Plated) / Ceramic	JW® Triplex Plunger / Brass / Ceramic
Motor Pump Coupling	type	Gearbox	Gearbox	Gearbox
Pump Speed	rpm	1450	1450	1450
Unloader Valve	type / material	Brass adjustable	Brass adjustable	Brass adjustable
Safety Valve	y / n	Y	Y	Y
Water Tank	l	50 (detachable)	50 (detachable)	50 (detachable)
Low Level Water Cut Out Protection	y / n	Y 12v	Y 12v	Y 12v

RANGE BUILD UP

OTHER FEATURES

Adjustable Pressure	y / n	Y	Y	Y
Hose Reel	features	Dual ball bearing supported welded hub	Dual ball bearing supported welded hub	Dual ball bearing supported welded hub
Primary Hose Reel Pressure Control	type	Ball valve and/or Remote Control	Ball valve and/or Remote Control	Ball valve and/or Remote Control
Frame Structure	type	CNC Modular skid with heavy gauge galavnised steel chassis and stainless steel cover	CNC Modular skid with heavy gauge galavnised steel chassis and stainless steel cover	CNC Modular skid with heavy gauge galavnised steel chassis and stainless steel cover

WARRANTY(S)

Engine Warranty	years			
Product	years			

*Coverage against defects in material and workmanship (refer to Jetwave's and component partners T&Cs).

PACKING DETAILS

DIMENSIONS AND WEIGHT

Approx weight	kg	250 unit / 305 boxed	250 unit / 305 boxed	280 unit / 305 boxed
Unit Dimensions	mm	1280(L) x 550(W) x 1320(H)	1280(L) x 550(W) x 1320(H)	1280(L) x 550(W) x 1320(H)
Box Dimensions <small>*Add 120mm to height for pallet.</small>	mm	1300(L) x 800(W) x 1400(H)	1300(L) x 800(W) x 1400(H)	1300(L) x 800(W) x 1400(H)

Number per Pallet	type: pieces	EURO: 1 	EURO: 1 	EURO: 1
-------------------	--------------	-------------	-------------	-------------

The manufacturer reserves the right to modify design features and technical facts without notice, due to our principals of continuous improvement.

@jetwave.group
#imagineCLEAN
#JetHydroHurricane



📍 10 - 16 Smith Street | Thebarton | Adelaide | South Australia | 5031 | AU
☎ +61 8 8371 3599 | ✉ sales@jetwave.com.au | 🌐 jetwavegroup.com



V2.1 08/2021

Jethydro® and Hurricane™ are registered trademarks of Jetwave® Group Pty Ltd.

For more information on our products, please visit jetwavegroup.com