



The NovaSaltMA is a multi-purpose submersible pump specifically constructed for use in salt water. Anti-corrosive and rust proof materials. Motor casing, shaft, screws and nuts made of stainless steel AISI 316. Excellent cooling of the motor that enables the pump to operate even when it is partially submersible. Automatic version with start/stop float switch. 10m power cable.

Electrical data:

Rated voltage: 240V
 Rated output: 0.2kW
 Power: 0.28hp
 Max Head: 7.0m
 Max Flow: 120L/m

Flexible Float Cable
 1 - 1/4" BSPF Outlet
 Adjustable Float - on 340mm, off 100mm

Materials:

Pump Body: PP OMO 30% FVAC NAT Grade 6 Stab. Therm.
 Impeller: PPO/PPE 20% FV
 Motor Shaft: Drawn bars steel INOX AISI 416
 OR Ring: NBR 70
 Filter: PP OMO 30% FVAC NAT Grade 18 Stab. Therm.
 Motor Casing: Sheet Metal Fe P01 0.65mm
 Ceramic Bushing: Drawn bars steel INOX AISI 416
 Upper Bearing Support: Die cast aluminium
 Lower Bearing Support: Die cast aluminium
 Filter Cover: PP Homopolymer Nat. Grade 10 MOPLEN HP
 Handle: PP20Tc

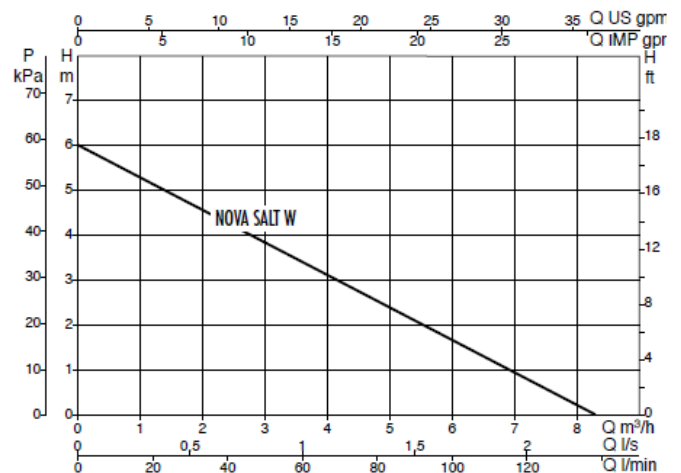

Dimensions:

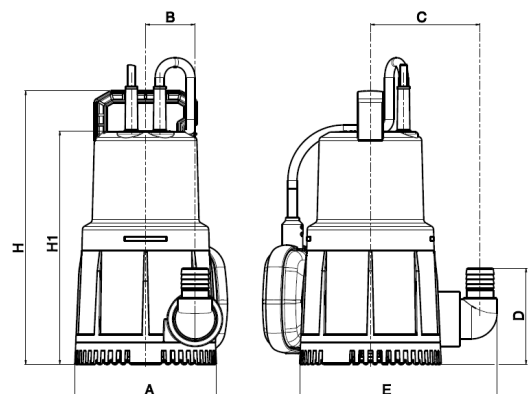

	A	B	C	D	E	H	HI	Cable	DNM GAS	Weight	Qty x Pallets
NOVA SALT MA	140	48	107	95	195	270	230	10m	1/4"	3kg	48

2 Year DAB Pump Warranty