

UN002607-DQ

KIT RICAMBI / PART KITS

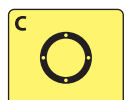
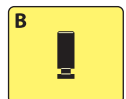
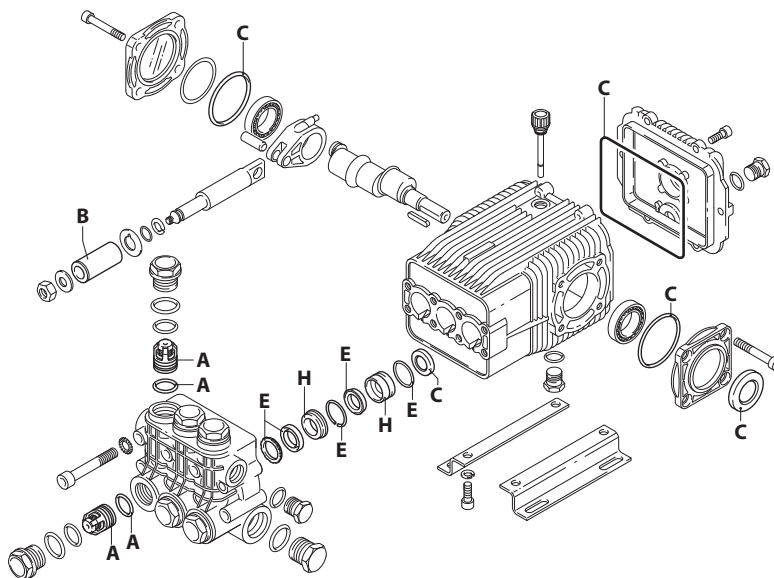

UN002608-DQ

194 Series

XW 1450 rpm N version ø 24 mm

15.15 (20352) 21.20 (20174) 26.12 (20175) 26.23 (20177) 30.20 DX (20060)
 15.20 (20353) 21.25 (20058) 26.15 (20176) 30.10 (20178) 30.20 SX (20270)
 15.30 (20592) 21.28 (21136) 26.20 (20059) 30.15 (20179) 30.25 (21137)



Pos.	Cod.	Denominazione	Description	Qt	Note	Pos.	Cod.	Denominazione	Description	Qt	Note		
1	1940260	Vite	TCEI M10x80	Screw	8	C=50Nm	33	1941330	Corpo pompa	Pump body	1		
2	650530	Rondella		Washer	8		34	1140370	Tappo	Plug	1		
3	1940140	Tappo		Plug	6	C=68Nm	35	1260250	Indicatore livello	Level gauge	1	⊕	
4	1940150	Anello antiestruzione		Ring	6		36	1260430	Anello	Ring	1	⊕	
5	1140450	Guarnizione OR	Ø 20,24x2,62	O-ring	12		37	1940410	Guarnizione OR	Ø 132x3	O-ring	1	
6	1949050	Valvola completa		Complete valve	6		38	1200430	Vite	TCEI M6x16	Screw	6	C=10,4 Nm
7	1940021	Testa		Head	1	● ◆ ○ ⊕	39	1949010	Coperchio completo	Cover	1		
	1941210	Testa		Head	1	▲	40	1780690	Disco	Plate	1	⊕	
8	550350	Guarnizione OR	Ø 23,81x2,62	O-ring	1		41	1140450	Guarnizione OR	Ø 20,24x2,62	O-ring	1	⊕
9	1140300	Tappo	3/4" G	Plug	1	C=35Nm	42	820680	Anello tenuta	Ring	1	(b)	
10	1980740	Tappo	3/8" G ottone	Plug	1	C=25Nm	43	1940560	Anello tenuta	Ring	3		
11	740290	Guarnizione OR	Ø 14x1,78	O-ring	3	⊕	44	1940370	Piede	Foot	2	Optional	
12	1940440	Guarnizione	Ø 20	Gasket	3	● ◆ ○ ⊕ (a)	45	1940380	Vite	TCEI 10x18	Screw	4	Optional C=50 Nm
	1940270	Guarnizione	Ø 22	Gasket	3	▲ (a)	46	200231	Rondella	Washer	4	Optional	
13	1940430	Guida pistone anteriore	Ø 20	Piston guide	3	● ◆ ○ ⊕	47	1941240	Supporto	Support	1		
	1940200	Guida pistone anteriore	Ø 22	Piston guide	3	▲	51	1941220	Guarnizione tagliato	Ø22	Gasket	3	
14	1940470	Guarnizione	Ø 20	Gasket	3	● ◆ ○ ⊕ (a)	60	1949200	Premontaggio testa	Head assembly	1	● ◆ ○ ⊕	
	1940480	Guarnizione	Ø 22	Gasket	3	▲ (a)		1949203	Premontaggio testa	Head assembly	1	▲	
15	1940450	Guida pistone posteriore	Ø 20	Piston guide	3	● ◆ ○ ⊕	75	1941270	Indicatore livello	Level gauge	1	④	
	1940460	Guida pistone posteriore	Ø 22	Piston guide	3	▲	76	100410	Guarnizione OR	Ø 34,6x2,62	O-ring	1	④
16	820490	Guarnizione OR	Ø 34,65x1,78	O-ring	3		77	1941260	Disco	Plate	1	④	
17	1940570	Dado		Nut	3	⊕ C=12Nm	78	1941290	Anello	Ring	1	④	
18	1940580	Rondella		Washer	3		82	1980740	Tappo	3/8" G ottone	Plug	2	⊕ C=20Nm
19	1420430	Pistone	Ø 20	Piston	3	● ◆ ○ ⊕							
	1420120	Pistone	Ø 22	Piston	3	▲							
20	880840	Guarnizione OR	Ø 9,25x1,78	O-ring	3								
21	960460	Disco		Plate	3								
22	1940120	Anello antiestruzione		Ring	3								
23	1940070	Pistone di guida		Piston	3								
24	1940060	Perno		Hub pin	3								
25	1941380	Guarnizione OR	Ø 66,34x2,62	O-ring	2								
26	1941390	Spessore 0,05 mm		Shim 0.05 mm	1÷3								
	1941400	Spessore 0,10 mm		Shim 0.10 mm	1÷3								
	1941410	Spessore 0,19 mm		Shim 0.19 mm	1÷3								
	1941420	Spessore 0,25 mm		Shim 0.25 mm	1÷3								
27	1949011	Coperchio		Cover	1								
28	850370	Vite	TCEI M8x16	Screw	8	C=24,5Nm							
29	1941370	Cuscinetto		Bearing	2	●							
	1140410	Cuscinetto		Bearing	2	◆ ○ ⊕ ▲							
30	1940051	Biella	alluminio	Connecting-rod	3	⊕ C=24,5Nm							
31	1940520	Albero	marcato 5	Shaft	1	● ◆							
	1940180	Albero	marcato 3	Shaft	1	○							
	1940160	Albero	marcato 1	Shaft	1	⊕ ▲							
32	650250	Linguetta		Key	1								

⊕ Compreso nel cod. 1949010 / Part of part n° 1949010

④ Compreso nel cod. 1949011 / Part of part n° 1949011

KIT RICAMBI - PART KITS

A=KIT 2780 valvole valves		B=KIT 2650 ø 20 pistoni pistons		B=KIT 1891 ø 22 pistoni pistons		C=KIT 2873 tenute olio oil seals	
Pos.	Q.ty	Pos.	Q.ty	Pos.	Q.ty	Pos.	Q.ty
5	6	19	3	19	3	25	2
6	6					37	1
						42	1
						43	3

E=KIT 2782 ø 20 tenute acqua water seals		E=KIT 2783 ø 22 tenute acqua water seals		H=KIT 2784 ø 20 guida pistoni pistons guide		H=KIT 2785 ø 22 guida pistoni pistons guide	
Pos.	Q.ty	Pos.	Q.ty	Pos.	Q.ty	Pos.	Q.ty
12	3	12	3	13	3	13	3
14	3	14	3	15	3	15	3
16	3	16	3				
51	3	51	3				

SIMBOLOGIA - SYMBOLS

Ø 20	Ø 20	Ø 20	Ø 22
● Per / For XW 15.15 cod. 20352 XW 15.20 cod. 20353	○ Per / For XW 21.20 cod. 20714 XW 21.25 cod. 20058 XW 21.28 cod. 21136	⊕ Per / For XW 26.12 cod. 20175 XW 26.15 cod. 20176 XW 26.20 cod. 20059 XW 26.23 cod. 20177	▲ Per / For XW 30.10 cod. 20178 XW 30.15 cod. 20179 XW 30.20 DX cod. 20060 XW 30.20 SX cod. 20270 XW 30.25 cod. 21137

- C Tolleranza coppia di serraggio +0÷-10% / Tightening torque tolerance +0÷-10%
- ⊕ Avvitare con Loxeal 55-14 / Screw with Loxeal 55-14
- ▲ Lubrificare con grasso Molykote PG54 solo sul diametro INTERNO / Lubricate with grease Molykote PG54 on the INNER diameter only
- (a) Montare con attrezzo speciale cod. 1940670 / Fit with special tool code nr. 1940670
- (b) Montare anello tenuta con attrezzo cod. 1941990 / Fit the seal with tool code nr. 1941990
- @ Posizionamento targa di identificazione / Identification plate positioning

Olio - Oil	
Tipo / Type	Quantità / Quantity
SAE 15W40	0,9 Kg